

PHILIPS

Data handbook



Electronic
components
and materials

Components and materials

Part 10 April 1978

Connectors

COMPONENTS AND MATERIALS

Part 10

April 1978

Connectors

ELECTRON TUBES (BLUE SERIES)

Part 1a	December 1975	ET1a 12-75	Transmitting tubes for communication, tubes for r.f. heating Types PE05/25 to TBW15/25
Part 1b	August 1977	ET1b 08-77	Transmitting tubes for communication, tubes for r.f. heating, amplifier circuit assemblies
Part 2	May 1976	ET2 05-76	Microwave products (This book is valid until Part 2b becomes available.)
Part 2a	November 1977	ET2a 11-77	Microwave tubes Communication magnetrons, magnetrons for microwave heating, klystrons, travelling-wave tubes, diodes, triodes T-R switches
Part 3	January 1975	ET3 01-75	Special Quality tubes, miscellaneous devices
Part 4	March 1975	ET4 03-75	Receiving tubes
Part 5a	March 1978	ET5a 03-78	Cathode-ray tubes Instrument tubes, monitor and display tubes, C.R. tubes for special applications
Part 5b	May 1975	ET5b 05-75	Camera tubes, image intensifier tubes
Part 6	January 1977	ET6 01-77	Products for nuclear technology Channel electron multipliers, neutron tubes, Geiger-Müller tubes
Part 7a	March 1977	ET7a 03-77	Gas-filled tubes Thyratrons, industrial rectifying tubes, ignitrons, high-voltage rectifying tubes
Part 7b	March 1977	ET7b 03-77	Gas-filled tubes Segment indicator tubes, indicator tubes, switching diodes, dry reed contact units
Part 8	May 1977	ET8 05-77	TV picture tubes
Part 9	March 1978	ET9 03-78	Photomultiplier tubes; phototubes

SEMICONDUCTORS AND INTEGRATED CIRCUITS (RED SERIES)





Part 1a	March 1976	SC1a 03-76	Rectifier diodes, thyristors, triacs Rectifier diodes, voltage regulator diodes ($> 1,5$ W), transient suppressor diodes, rectifier stacks, thyristors, triacs
Part 1b	May 1977	SC1b 05-77	Diodes Small signal germanium diodes, small signal silicon diodes, special diodes, voltage regulator diodes ($< 1,5$ W), voltage reference diodes, tuner diodes
Part 2	November 1977	SC2 11-77	Low-frequency and dual transistors
Part 3	January 1978	SC3 01-78	High-frequency, switching and field-effect transistors
Part 4a	June 1976	SC4a 06-76	Special semiconductors Transmitting transistors, field-effect transistors, dual transistors, microminiature devices for thick and thin-film circuits
Part 4b	July 1976	SC4b 07-76	Devices for optoelectronics Photosensitive diodes and transistors, light emitting diodes, displays, photocouplers, infrared sensitive devices, photoconductive devices
Part 5a	November 1976	SC5a 11-76	Professional analogue integrated circuits
Part 5b	March 1977	SC5b 03-77	Consumer integrated circuits Radio-audio, television
Part 6	October 1977	SC6 10-77	Digital integrated circuits LOCMOS HE4000B family
Signetics integrated circuits 1976			Logic, Memories, Interface, Analogue, Microprocessor, Milrel

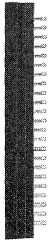

COMPONENTS AND MATERIALS (GREEN SERIES)

Part 1	June 1977	CM1 06-77	Assemblies for industrial use High noise immunity logic FZ/30-series, counter modules 50-series, NORbits 60-series, 61-series, circuit blocks 90-series, circuit block CSA70(L), PLC modules, input/output devices, hybrid circuits, peripheral devices, ferrite core memory products
Part 2a	October 1977	CM2a 10-77	Resistors Fixed resistors, variable resistors, voltage dependent resistors (VDR), light dependent resistors (LDR), negative temperature coefficient thermistors (NTC), positive temperature coefficient thermistors (PTC), test switches
Part 2b	February 1978	CM2b 02-78	Capacitors Electrolytic and solid capacitors, film capacitors, ceramic capacitors, variable capacitors
Part 3	January 1977	CM3 01-77	Radio, audio, television FM tuners, loudspeakers, television tuners and aerial input assemblies, components for black and white television, components for colour television
Part 4a	October 1976	CM4a 10-76	Soft ferrites Ferrites for radio, audio and television, beads and chokes, Ferroxcube potcores and square cores, Ferroxcube transformer cores
Part 4b	December 1976	CM4b 12-76	Piezoelectric ceramics, permanent magnet materials
Part 5	July 1975	CM5 07-75	Ferrite core memory products Ferroxcube memory cores, matrix planes and stacks, core memory systems
Part 6	April 1977	CM6 04-77	Electric motors and accessories Small synchronous motors, stepper motors, miniature direct current motors
Part 7	September 1971	CM7 09-71	Circuit blocks Circuit blocks 100 kHz-series, circuit blocks 1-series, circuit blocks 10-series, circuit blocks for ferrite core memory drive
Part 8	February 1977	CM8 02-77	Variable mains transformers
Part 9	March 1976	CM9 03-76	Piezoelectric quartz devices
Part 10	April 1978	CM10 04-78	Connectors

Connectors

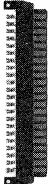

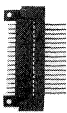
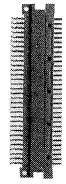
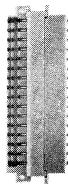
SURVEY

type	type number	pitch mm (in)			number of contacts	terminations			current at 20 °C A	mechanical endurance (insertions)
		2,54 (0,1)	3,81 (0,15)	3,96 (0,156)		5,08 (0,2)	solder tags	dip-solder pins		
PRINTED-WIRING CONNECTORS										
	F044	•			4 to 37 (bridged)	•	•		3	300
	F045		•		1 to 54 (single row) 2 to 108 (double row)		•		4,5	300
	F046	•			4 to 45 (single row) 8 to 90 (double row)		•		4,5	300
	F047			•	6, 10, 15, 18, 22 (single row) 12, 20, 30, 36, 44 (double row) 6, 10, 15, 18, 22 (bridged)		•		5,5	250
	F050			•	6, 10, 15, 18, 22 (single row) 12, 20, 30, 36, 44 (double row) 6, 10, 15, 18, 22 (bridged)		•		5,5	100
	F053			•	6, 10, 15, 18, 22, 28, 36, 43 (single row) 12, 20, 30, 36, 44, 56, 72, 86 (double row)		•	•	4	250
PRINTED-WIRING INTERCONNECTORS										
	F051			•	6, 10, 15, 18, 22 (single row) 12, 20, 30, 36, 44 (double row)		•		5,5	300

type	type number	pitch mm (in)			number of contacts	terminations			current at 20 °C A	mechanical endurance (insertions)
		2,54 (0,1)	3,81 (0,15)	3,96 (0,156)		5,08 (0,2)	solder tags	dip-solder pins		
TWO-PART PRINTED-WIRING CONNECTORS										
	F054*	•			32, 48, 64 (double row)	•	•	•	3,5	300
	F068-I	•			32, 64 (style B) 32 (style C) 64, 96 (style C)	•	•	•	2	400 (IEC/DIN) 500 (VG)
	F068-II				32, 48 (style F) 64 (style G)	•		•	5,5	400
	F080		•		32, 42 (double row)			•	2,5	500
	F081	•			48, 64 (double row)			•	2	500

* Maintenance type.

CONNECTORS

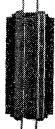
type	type number	pitch mm (in)			number of contacts	terminations			current at 20 °C A	mechanical endurance (insertions)
		2,54 (0,1)	3,81 (0,15)	3,96 (0,156)		5,08 (0,2)	solder tags	dip-solder pins		
TWO-PART JUMPER CONNECTOR										
	F088				2				3	150
MODULAR CONNECTOR SYSTEM										
	F095				board edge socket: 2 to 32 (single row) 4 to 130 (double row) panel socket: 2 to 32 (single row) 4 to 100 (double row) cable connector: 4 to 64 (double row) male header, straight pins: 2 to 32 (single row) 4 to 64 (double row) mounting block for pins: 8, 12, 20 (double row) male header, 90° angled pins: 15 (single row) 30 (double row)				3	300
SUBMINIATURE RACK AND PANEL CONNECTORS										
	F161				9, 15, 25, 37, 50				7,5	500

GLOSSARY OF TERMS

This glossary covers most of the terms used in this data handbook. For comprehensive explanation of terms reference is made to IEC 581, from which the greater part of this glossary is derived.

Bifurcated contact — Flat contact with a lengthwise slot, the two arms of which apply contact force in the same direction.

Clearance — Path through the air between two contacts.

Coding parts — Parts to be used with two-part connectors to code, and guide mating connector parts during mating, preventing incorrect insertion.

Connector body — Connector less its contacts.

Connector insert — Insulating element designed to support and position the contacts in the connector.

Contact — Conductive element in the connector which mates with a corresponding element to provide an electrical path.

Contact force — Normal force (90°) which exists between engaged contact surfaces.

Contact pitch — Distance between contact centres.

Contact resistance — Electrical resistance of a mated set of contacts under specified conditions.

Contact retention force — Axial force withstanding extraction of a removable contact from a connector.

Contact spring — Contact having elastic properties to provide a force to its mating part.

Contact surface — Area in contact between two mated contacts or a contact and a conductor, which provides an electrical path.

Creepage distance — Path across the surface of the connector body between two contacts.

Crimp contact — Contact having a conductor barrel designed to be crimped.

Derated current curve — Maximum current curve, which is 20% derated from the basic current carrying capacity, taking into account errors in temperature measurements in the equipment, and external factors e.g. wire sizes and unequal distribution of loaded circuits.

Dip-solder pin — Contact with a termination intended to be bath-soldered.

Female contact — Contact intended to make electrical engagement on its inner surface, and which will accept entry of a male contact.

Female part — Part of a two-part connector provided with female contacts for mating the contacts of the male part.

Grid — Orthogonal network of two sets of parallel equidistant lines for positioning connections on a printed board.

Insertion force — Force to insert fully a set of mating components without the effect of a coupling, locking or similar device.

Male contact — Contact intended to make electrical engagement on its outer surface, and which will enter a female contact.

Male part — Part of a two-part connector provided with male contacts for mating the contacts of the female part.

Panel cut-out — Hole or group of holes cut in a panel or chassis for mounting a connector.

Pin for wire wrapping — Contact with a termination designed to accept a wrapped connection.

Polarization — Features on mating components to prevent incorrect mating.

Polarization key — Device providing mating of two components in the correct way.

Printed-wiring connector — Connector provided with female contacts for mating with contacts on the edge of a printed-wiring board.

Printed-wiring interconnector — Connector provided on one side with female contacts for mating with contacts on the edge of a printed-wiring board, and on the other side with male contacts for mating with contacts of a receptacle.

Protruding earth contact — Contact pin of a male part which is longer than the other pins, preventing damage of sensitive components, when inserting the male part into the female part.

Rack and panel connector — Two-part connector intended to provide a connection between a unit and its mounting rack; normally the connector parts are engaged by the movement between the unit and the rack.

Solder cup — Contact termination having a cup or hollow cylinder to accept a wire and retain the applied solder.

Solder tag — Contact termination provided with an eyelet designed for attachment of the conductor by soldering.

Termination — Part of the contact to which a conductor is normally connected.

Tuning fork contact — Resilient contact having a shape similar to that of a tuning fork, the two arms of which apply contact force in opposite directions.

Two-part connector — Connector which consists of a mating pair of parts; one part is mechanically and electrically connected to a printed board, and the other part is mounted as required by equipment practice.

Withdrawal force — Force to withdraw fully a set of mating components without the effect of a coupling, locking or similar device.

PRINTED-WIRING CONNECTORS

- 2,54 mm (0,1 in) pitch

QUICK REFERENCE DATA

Contact pitch	2,54 mm (0,1 in)
Number of contacts	4 to 37
Board thickness	1,42 to 1,78 mm
Terminations	solder tags dip-solder pins
Current at $T_{amb} = 20\text{ }^{\circ}\text{C}$	3 A
Mechanical endurance	300 insertions
Climatic category (IEC 68)	25/085/21

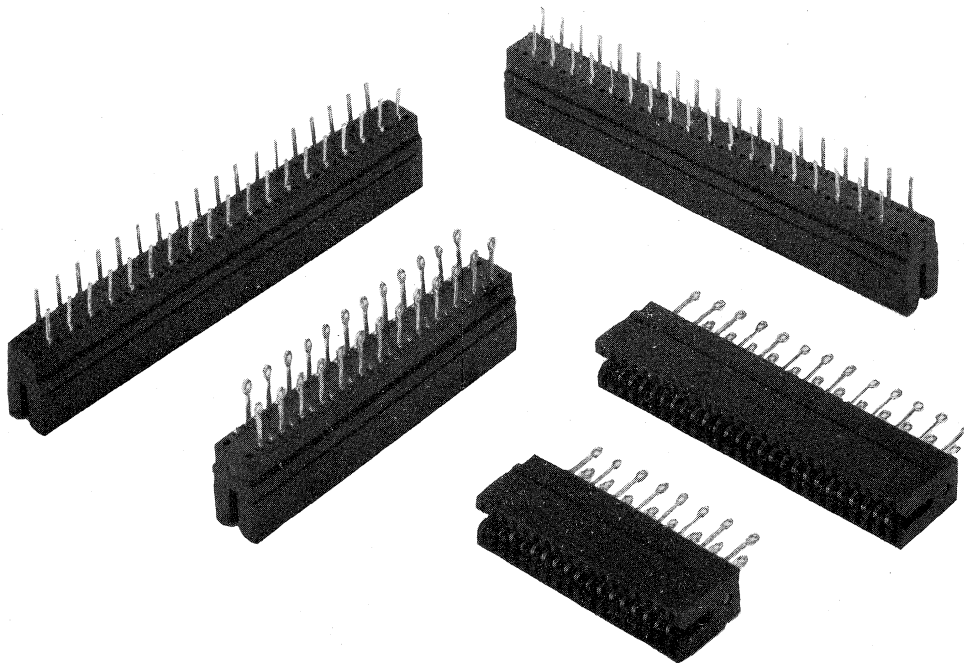

APPLICATION

For use in telecommunication, data processing and industrial equipment.

DESCRIPTION

The connectors have a body of black tropic-proof thermosetting phenolic resin. The contact springs are of phosphor bronze wire. The opposite contacts are bridged to provide a four-fold contact. The contact surfaces are gold plate on nickel plate.

ELECTRICAL DATA

Current at $T_{amb} = 20\text{ }^{\circ}\text{C}$	3 A
Derated current curve	according to IEC 512-3, test 5b, see Fig. 1
<p>Contact resistance (including material resistance) at 10 mA, max. 20 mV (peak) open circuit voltage, 1 kHz.</p> <p>Measured outside the body:</p> <ul style="list-style-type: none"> initially $\leq 10\text{ m}\Omega$ after mechanical endurance $\leq 12\text{ m}\Omega$ after damp heat test $\leq 12\text{ m}\Omega$ 	
<p>Insulation resistance</p> <ul style="list-style-type: none"> initially $> 10^4\text{ M}\Omega$ after damp heat test $> 10^2\text{ M}\Omega$ 	
Creepage distance between adjacent contacts	$\geq 1,3\text{ mm}$
Clearance between adjacent contacts	$\geq 1,3\text{ mm}$
<p>Proof voltage for 1 min, at $20\text{ }^{\circ}\text{C}$</p> <ul style="list-style-type: none"> between adjacent contacts 650 V (r.m.s.), 50 Hz between a contact and earth 650 V (r.m.s.), 50 Hz 	
Capacitance between adjacent contacts at 1 kHz	$\leq 2\text{ pF}$

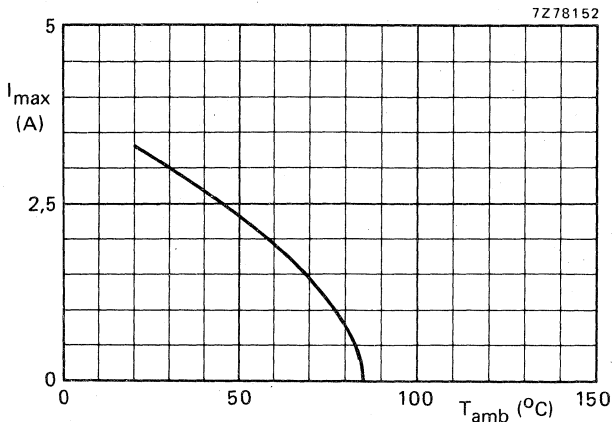

Fig. 1 Maximum current per contact, equally on all contacts, as a function of ambient temperature (20% derated).

MECHANICAL DATA

Contact pitch	2,54 mm (0,1 in)
Number of contacts	4 to 37
Board thickness	1,42 to 1,78 mm
Polarization	by means of a polarizing key (Fig. 10)
Mechanical endurance	300 insertions
Connector body material	tropic-proof phenolic resin
Contact springs	
material	phosphor bronze
shape	tuning fork
finish of contact surfaces	≥ 0,8 μm gold plate on ≥ 2 μm nickel plate
contact force	≥ 1 N
type of termination	solder tag or dip-solder pin
finish of termination	tinned
Solderability	235 °C, 2 s
Resistance to heat	260 °C, 5 s
	} according to IEC 68, test T

ENVIRONMENTAL DATA

Climatic category (IEC 68)	25/085/21
Ambient temperature range	-25 to + 85 °C
Damp heat, steady state	according to IEC 68, test Ca, 21 days, 40 °C, R.H. 90 to 95%
Dry heat	according to IEC 68, test Ba, 16 h, 85 °C
Flammability	according to UL94, category V0

DIMENSIONAL DATA

Dimensions in mm

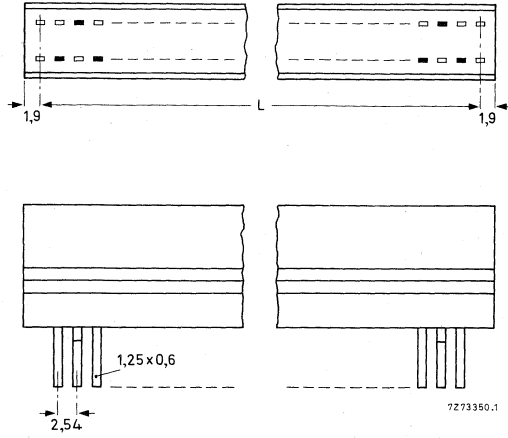
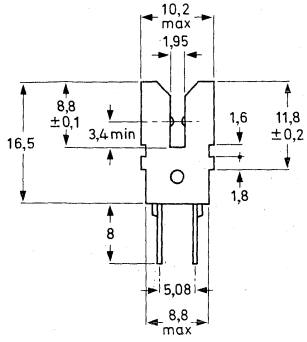

Fig. 2a Connector with dip-solder pins. See Table 1 for dimension L.

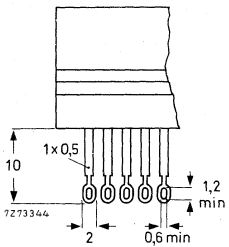

Fig. 2b Connector with solder tags.

Note

In view of the use of mounting brackets the connectors are supplied without contacts at the ends.

Table 1

number of contacts	L		catalogue number	
	L _{nom}	tolerance	connectors with dip-solder pins	connectors with solder tags
4	12,70	± 0,2	2422 021 40618	2422 023 40618
5	15,24		40718	40718
6	17,78		40818	40818
7	20,32		40918	40918
8	22,86		41018	41018
9	25,40		41118	41118
10	27,94		41218	41218
11	30,48		41318	41318
12	33,02		41418	41418
13	35,56		41518	41518
14	38,10		41618	41618
15	40,64		41718	41718
16	43,18		41818	41818
17	45,72		41918	41918
18	48,26		42018	42018
19	50,80		42118	42118
20	53,34		42218	42218
21	55,88		42318	42318
22	58,42		42418	42418
23	60,96		42518	42518
24	63,50		42618	42618
25	66,04		42718	42718
26	68,58		42818	42818
27	71,12		42918	42918
28	73,66		43018	43018
29	76,20		43118	43118
30	78,74		43218	43218
31	81,28		43318	43318
32	83,82		43418	43418
33	86,36		43518	43518
34	88,90		43618	43618
35	91,44		43718	43718
36	93,98		43818	43818
37	96,52		43918	43918

MOUNTING

Mounting brackets

Two types of mounting brackets are available:

- metal bracket for rail or panel mounting, catalogue number 4332 026 00750 (Figs 3 and 4);
- metal bracket for panel mounting, catalogue number 4332 026 00760 (Figs 5 and 6).

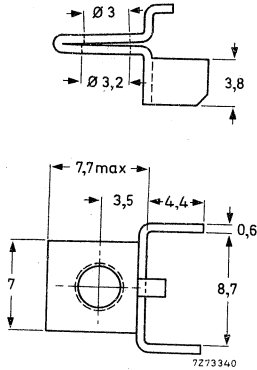

Fig. 3 Metal mounting bracket 4332 026 00750.

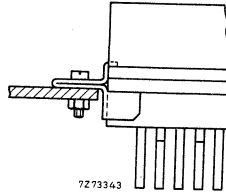

Fig. 4 Part view, showing mounting bracket in position.

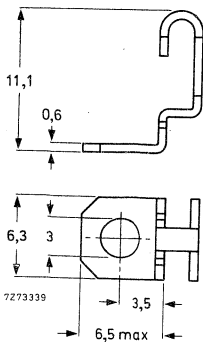

Fig. 5 Metal mounting bracket 4332 026 00760.

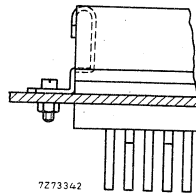

Fig. 6 Part view, showing mounting bracket in position.

Piercing diagrams

In Figs 7 and 8, piercing diagrams are given for connectors with mounting brackets as shown in Figs 3 and 5.

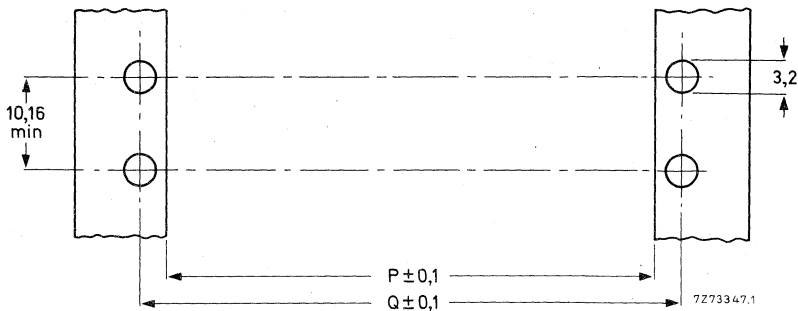

Fig. 7 Piercing diagram for rail mounting; see Table 2 for dimensions P and Q.

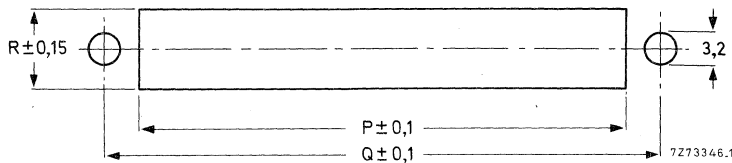

Fig. 8 Piercing diagram for panel mounting; see Table 2 for dimensions P, Q and R.

Table 2

bracket used	dimensions (mm)		
	P	Q	R
4332 026 00750 (Fig. 3)	$L_{nom} + 5,8$	$L_{nom} + 10,8$	10,5
4332 026 00760 (Fig. 5)	$L_{nom} + 4,4$	$L_{nom} + 10,8$	9

See Table 1 for L_{nom} .

Printed-wiring board recommendations

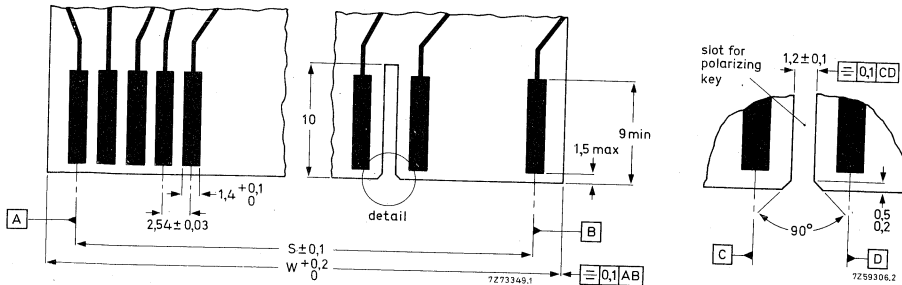

Fig. 9 Recommended dimensions of the printed-wiring board; $S = L_{nom} - 5,08$ mm, $W = L_{nom} - 0,6$ mm. For L_{nom} see Table 1.

POLARIZATION AND POSITIONING

A metal key (Fig. 10) fitted over a contact spring ensures that a printed-wiring board is correctly polarized in its connector. A slot must be made in the printed-wiring board to receive the key (Fig. 9).

The same key is also recommended for positioning of the board when using connectors mounted with brackets 4332 026 00750, for example.

Catalogue number of polarizing key: 4332 026 00770.

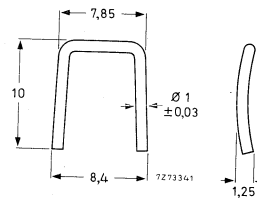

Fig. 10 Polarizing key.

MARKING

The package is marked with:
 12-digit catalogue number;
 reference number of manufacturer;
 number of pieces.

PRINTED-WIRING CONNECTORS

- 5,08 mm (0,2 in) pitch

QUICK REFERENCE DATA

Contact pitch	5,08 mm (0,2 in)
Number of contacts	
single row	1 to 54
double row	2 to 108
Board thickness	1,42 to 1,78 mm
Terminations	solder tags
Current at $T_{amb} = 20\text{ }^{\circ}\text{C}$	4,5 A
Mechanical endurance	300 insertions
Climatic category (IEC 68)	25/085/21

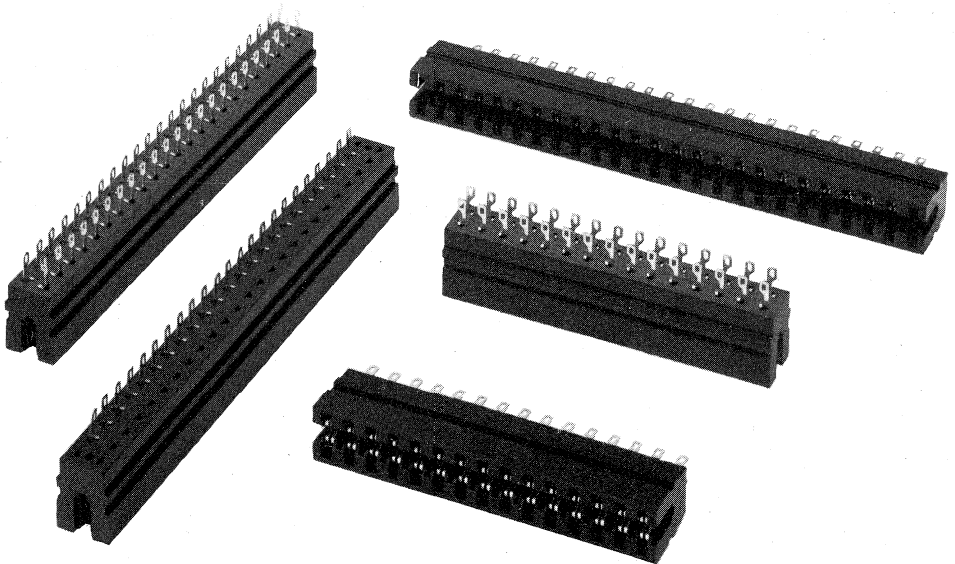

APPLICATION

For use in telecommunication, data processing and industrial equipment.

DESCRIPTION

The connectors have a moulded body of black, tropic-proof thermosetting phenolic resin. The contact springs are of phosphor bronze; they are bifurcated to provide a double contact and are removable. The contact surfaces are gold plate on nickel plate.

ELECTRICAL DATA

Current at $T_{amb} = 20\text{ }^{\circ}\text{C}$	4,5 A
Derated current curve	according to IEC 512-3, test 5b, see Fig. 1
<p>Contact resistance (including material resistance) at 10 mA, max. 20 mV (peak) open circuit voltage, 1 kHz.</p> <p>Measured outside the body:</p> <ul style="list-style-type: none"> initially $\leq 12\text{ m}\Omega$ after mechanical endurance $\leq 12\text{ m}\Omega$ after damp heat test $\leq 14\text{ m}\Omega$ 	
<p>Insulation resistance</p> <ul style="list-style-type: none"> initially $> 10^4\text{ M}\Omega$ after damp heat test $> 10^2\text{ M}\Omega$ 	
Creepage distance between contacts	$\geq 2,6\text{ mm}$
Clearance between contacts	$\geq 0,5\text{ mm}$
<p>Proof voltage for 1 min, at $20\text{ }^{\circ}\text{C}$</p> <ul style="list-style-type: none"> between adjacent or opposite contacts 1000 V (r.m.s.), 50 Hz between a contact and earth 1000 V (r.m.s.), 50 Hz 	
Capacitance between contacts at 1 kHz	$\leq 1\text{ pF}$

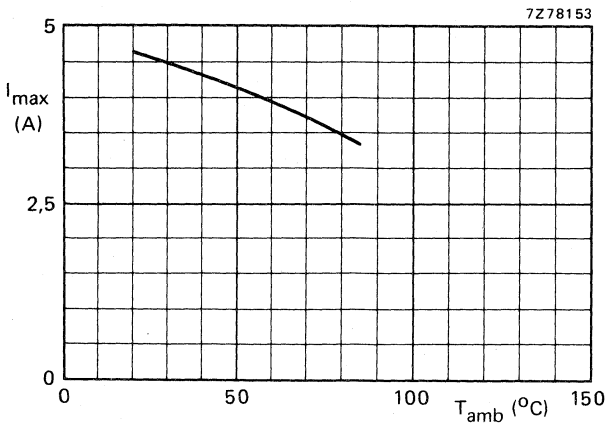

Fig. 1 Maximum current per contact, equally on all contacts, as a function of ambient temperature (20% derated).

MECHANICAL DATA

Contact pitch	5,08 mm (0,2 in)
Number of contacts	
single row	1 to 54
double row	2 to 108
Board thickness	1,42 to 1,78 mm
Polarization	by means of a polarizing key
Mechanical endurance	300 insertions
Connector body material	tropic-proof phenolic resin
Contact springs	
material	phosphor bronze
shape	bifurcated
finish of contact surfaces	≥ 0,75 μm gold plate on
	≥ 5 μm nickel plate
contact force	≥ 1 N
type of terminations	solder tag
finish of terminations	gold flash
Solderability	235 °C, 2 s
Resistance to soldering heat	350 °C, 10 s
Shock	according to IEC 68, test Ea, 50g, 11 ms
Vibration	according to IEC 68, test Fc, 10 to 2000 Hz, 0,75 mm (p-p) or 10 g, 3 directions, 6 h per direction

ENVIRONMENTAL DATA

Climatic category (IEC 68)	25/085/21
Ambient temperature range	-25 to + 85 °C
Damp heat, steady state	according to IEC 68, test Ca, 21 days, 40 °C, R.H. 90 to 95%
Flammability	according to UL94, category V0

DIMENSIONAL DATA

Dimensions in mm

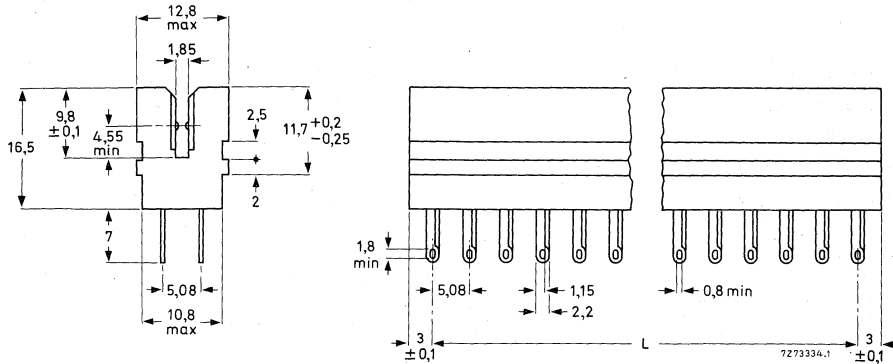

Fig. 2 Double row connector. See Table 1 for dimension L. For the single row version, one row of contact springs is omitted.

Table 1

number of contacts		L		catalogue number	
single row	double row	L _{nom}	tol.	single row	double row
3	6	10,16	± 0,20	2422 020 50302	2422 020 50312
4	8	15,24		50402	50412
5	10	20,32		50502	50512
6	12	25,40		50602	50612
7	14	30,48		50702	50712
8	16	35,56		50802	50812
9	18	40,64		50902	50912
10	20	45,72		51002	51012
11	22	50,80		51102	51112
12	24	55,88		51202	51212
13	26	60,96		51302	51312
14	28	66,04		51402	51412
15	30	71,12		51502	51512
16	32	76,20		51602	51612
17	34	81,28	± 0,30	51702	51712
18	36	86,36		51802	51812
19	38	91,44		51902	51912
20	40	96,52		52002	52012
21	42	101,60		52102	52112
22	44	106,68		52202	52212
23	46	111,76		52302	52312
24	48	116,84		± 0,40	52402
25	50	121,92	52502		52512

Table 1 (continued)

number of contacts		L		catalogue number	
single row	double row	L _{nom}	tol.	single row	double row
26	52	127,00	± 0,40	2422 020 52602	2422 020 52612
27	54	132,08		52702	52712
28	56	137,16		52802	52812
29	58	142,24		52902	52912
30	60	147,32		53002	53012
31	62	152,40		53102	53112
32	64	157,48		53202	53212
33	66	162,56		53302	53312
34	68	167,64		53402	53412
35	70	172,72		53502	53512
36	72	177,80		53602	53612
37	74	182,88		53702	53712
38	76	187,96		53802	53812
39	78	193,04		53902	53912
40	80	198,12	54002	54012	
41	82	203,20	54102	54112	
42	84	208,28	54202	54212	
43	86	213,36	54302	54312	
44	88	218,44	54402	54412	
45	90	223,52	± 0,50	54502	54512
46	92	228,60		54602	54612
47	94	233,68		54702	54712
48	96	238,76		54802	54812
49	98	243,84		54902	54912
50	100	248,92		55002	55012
51	102	254,00		55102	55112
52	104	259,08		55202	55212
53	106	264,16		55302	55312
54	108	269,24		55402	55412

Note

In view of the use of mounting brackets, all connectors given in Table 1 can also be supplied without contacts at the ends. For ordering these versions, replace last digit of the catalogue number by 4.

MOUNTING

Mounting brackets

For mounting brackets to be used with connector F045, see Table 2.

Table 2

mounting application	mounting bracket		catalogue number
	according to Fig.	material	
rail or panel	3	thermoplastic	4332 026 11110
rail or panel	5	metal	4332 026 04760
panel	7	metal	4332 026 04750*
panel	9 and 10	metal	4332 026 04630* (bracket) and 4332 026 04770* (end piece)

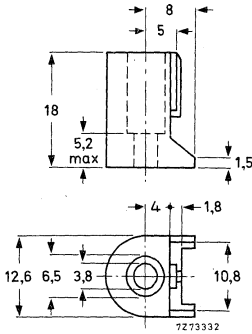

Fig. 3 Thermoplastic mounting bracket 4332 026 11110.

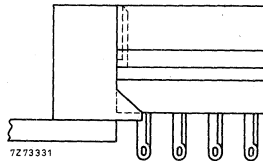

Fig. 4 Part view, showing mounting bracket in position.

* Only to be used with connectors without end contacts.

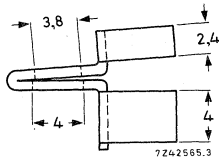
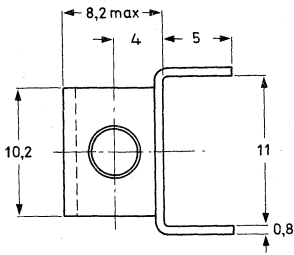

Fig. 5 Metal mounting bracket 4332 026 04760.

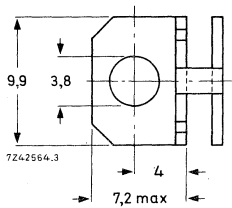
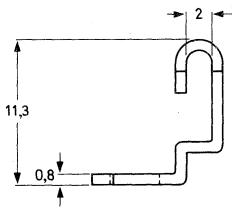

Fig. 7 Metal mounting bracket 4332 026 04750.

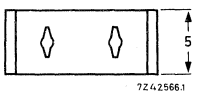
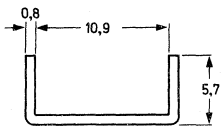

Fig. 9 Metal mounting bracket 4332 026 04630.

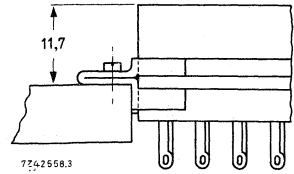

Fig. 6 Part view, showing mounting bracket in position.

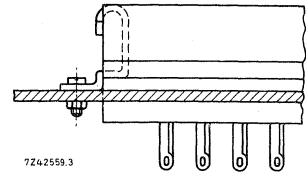

Fig. 8 Part view, showing mounting bracket in position.

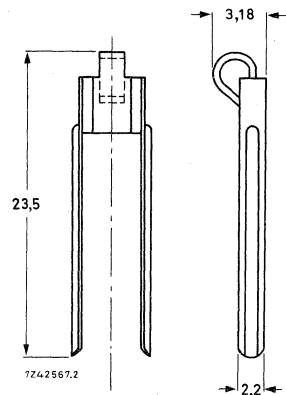

Fig. 10 End piece 4332 026 04770.



Fig. 11 Part views, showing mounting bracket and end piece in position.

Piercing diagrams

In Figs 12 and 13, piercing diagrams are given for connectors with mounting brackets as shown in Figs 3 to 11.

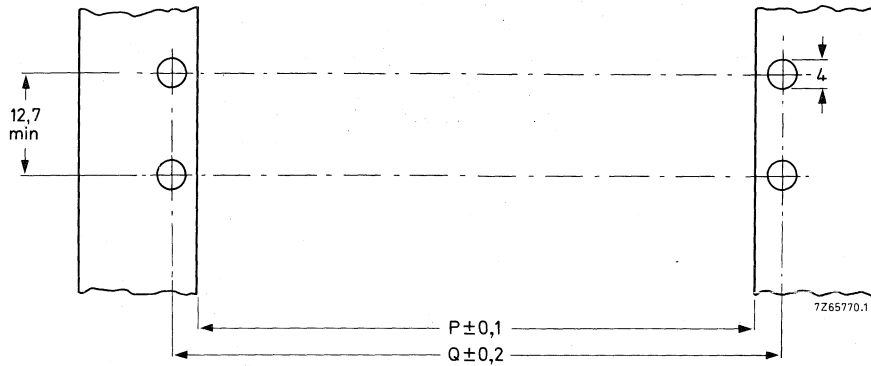

Fig. 12 Piercing diagram for rail mounting; see Table 3 for dimensions P and Q.

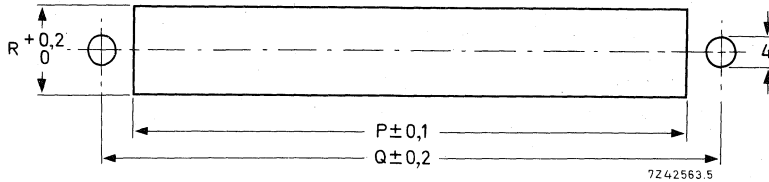

Fig. 13 Piercing diagram for panel mounting; see Table 3 for dimensions P, Q and R. If bracket 4332 026 04630 and end piece 4332 026 04770 are used the circular holes are superfluous.

Table 3

bracket used	dimensions (mm)		
	P	Q	R
4332 026 11110	$L_{max} + 6,2$	$L_{nom} + 14$	11,0
04760	$L_{max} + 7,8$	$L_{nom} + 14$	12,8
04750	$L_{max} + 6,2$	$L_{nom} + 14$	11,0
04630	$L_{max} + 6,2$	$L_{nom} + 14$	11,0
04770			

See Table 1 for L_{nom} and L_{max} .

Printed-wiring board recommendations

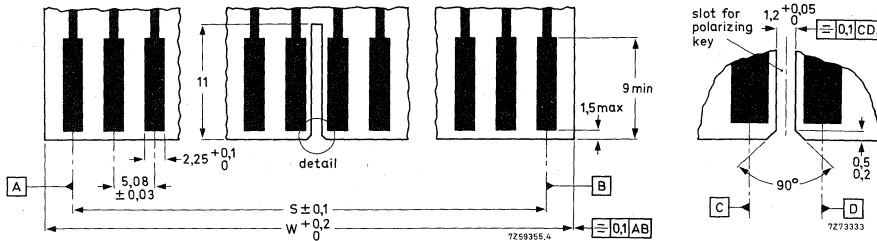

Fig. 14 Recommended dimensions of the printed-wiring board; see Table 4 for dimensions S and W.

Table 4

bracket used	dimensions (mm)	
	S	W
4332 026 11110	L_{nom}	$L_{min} + 1,9$
04760	L_{nom}	$L_{min} + 5,5$
04750	$L_{nom} - 10,16$	$L_{min} - 0,1$
04630	$L_{nom} - 10,16$	$L_{min} - 0,15$
04770		

See Table 1 for L_{nom} and L_{min} .

POLARIZATION AND POSITIONING

A thermoplastic key (Fig. 15) inserted in a slot between any two adjacent contacts ensures that a printed-wiring board is correctly polarized in its connector. This method involves no loss of contacts. A slot must be made in the printed-wiring board to receive the key (Fig. 14).

The same key is also recommended for positioning of the board when using connectors with more than 35 contacts (single row) or 70 contacts (double row). In this case the slot in the printed-wiring board should be near the centre.

Catalogue number of polarizing key: 4332 026 04740.

MARKING

The package is marked with:
 12-digit catalogue number;
 reference number of manufacturer;
 number of pieces.

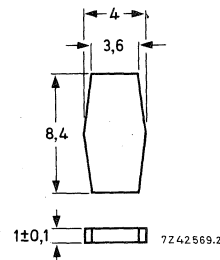

Fig. 15 Polarizing key.

PRINTED-WIRING CONNECTORS

- 3,81 mm (0,15 in) pitch

QUICK REFERENCE DATA

Contact pitch	3,81 mm (0,15 in)
Number of contacts	
single row	4 to 45
double row	8 to 90
Board thickness	1,42 to 1,78 mm
Terminations	solder tags
Current at $T_{amb} = 20\text{ }^{\circ}\text{C}$	4,5 A
Mechanical endurance	300 insertions
Climatic category (IEC 68)	25/085/21

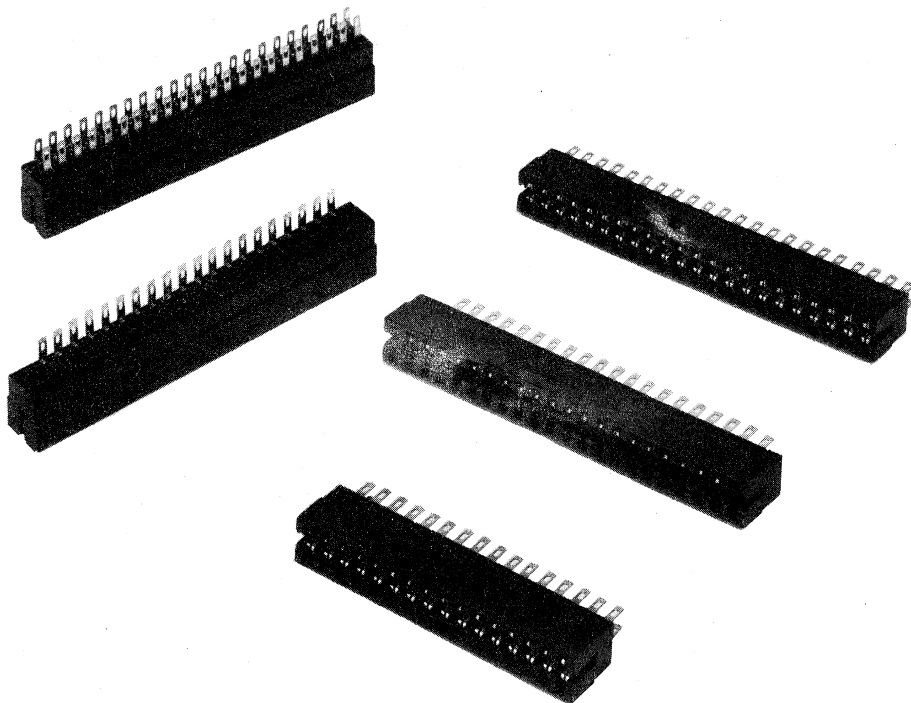

APPLICATION

For use in telecommunication, data processing and industrial equipment.

DESCRIPTION

The connectors have a moulded body of black, tropic-proof thermosetting phenolic resin. The contact springs are of phosphor bronze; they are bifurcated to provide a double contact and are removable. The contact surfaces are gold plate on nickel plate.

ELECTRICAL DATA

Current at $T_{amb} = 20\text{ }^{\circ}\text{C}$	4,5 A
Derated current curve	according to IEC 512-3, test 5b, see Fig. 1
Contact resistance (including material resistance) at 10 mA, max. 20 mV (peak) open circuit voltage, 1 kHz.	
Measured outside the body:	
initially	$\leq 10\text{ m}\Omega$
after mechanical endurance	$\leq 10\text{ m}\Omega$
after damp heat test	$\leq 12\text{ m}\Omega$
Insulation resistance	
initially	$> 10^4\text{ M}\Omega$
after damp heat test	$> 10^2\text{ M}\Omega$
Creepage distance between contacts	$\geq 1,8\text{ mm}$
Clearance between contacts	$\geq 0,4\text{ mm}$
Proof voltage for 1 min, at $20\text{ }^{\circ}\text{C}$	
between contacts	1000 V (r.m.s.), 50 Hz
between a contact and earth	1000 V (r.m.s.), 50 Hz
Capacitance between contacts at 1 kHz	$\leq 2\text{ pF}$

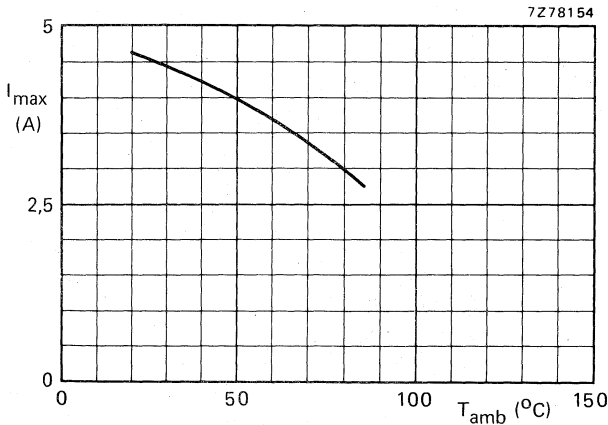

Fig. 1 Maximum current per contact, equally on all contacts, as a function of ambient temperature (20% derated).

MECHANICAL DATA

Contact pitch	3,81 mm (0,15 in)
Number of contacts	
single row	4 to 45
double row	8 to 90
Board thickness	1,42 to 1,78 mm
Polarization	by means of a polarizing key (Fig. 10)
Mechanical endurance	300 insertions
Connector body material	tropic-proof phenolic resin
Contact springs	
material	phosphor bronze
shape	bifurcated
finish of contact surfaces	$\geq 0,8 \mu\text{m}$ gold plate on $\geq 5 \mu\text{m}$ nickel plate
contact force	$\geq 0,8 \text{ N}$
type of termination	solder tag
finish of termination	gold flash
Solderability	235 °C, 2 s
Resistance to soldering heat	350 °C, 10 s
Shock	235 °C, 2 s } according to IEC 68, test T
Vibration	350 °C, 10 s } according to IEC 68, test Ea, 50g, 11 ms
	according to IEC 68, test Fc, 10 to 2000 Hz,
	0,75 mm (p-p) or 10g, 3 directions, 6 h per direction

ENVIRONMENTAL DATA

Climatic category (IEC 68)	25/085/21
Ambient temperature range	-25 to + 85 °C
Damp heat, steady state	according to IEC 68, test Ca, 21 days, 40 °C, R.H. 90 to 95%
Flammability	according to UL94, category V0

DIMENSIONAL DATA

Dimensions in mm

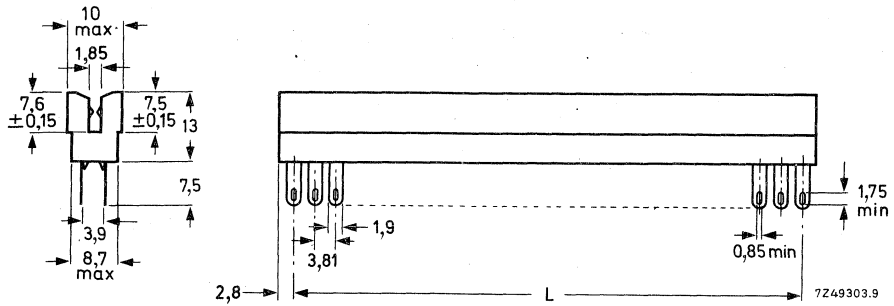

Fig. 2 Double row connector. See Table 1 for dimension L. For the single row version, one row of contact springs is omitted.

Table 1

number of contacts		L		catalogue number	
single row	double row	L _{nom}	tolerance	single row	double row
6	12	19,05	± 0,15	2422 036 60602	2422 036 60612
7	14	22,86		60702	60712
8	16	26,67		60802	60812
9	18	30,48		60902	60912
10	20	34,29		61002	61012
11	22	38,10		61102	61112
12	24	41,91		61202	61212
13	26	45,72		61302	61312
14	28	49,53		61402	61412
15	30	53,34		61502	61512
16	32	57,15	61602	61612	
17	34	60,96	61702	61712	
18	36	64,77	61802	61812	
19	38	68,58	61902	61912	
20	40	72,39	62002	62012	
21	42	76,20	62102	62112	
22	44	80,01	62202	62212	
23	46	83,82	62302	62312	
24	48	87,63	62402	62412	
25	50	91,44	62502	62512	
26	52	95,25	62602	62612	
27	54	99,06	62702	62712	
28	56	102,87	62802	62812	
29	58	106,68	62902	62912	
30	60	110,49	63002	63012	
31	62	114,30	63102	63112	
32	64	118,11	63202	63212	
33	66	121,92	63302	63312	
34	68	125,73	63402	63412	
35	70	129,54	63502	63512	
36	72	133,35	63602	63612	
37	74	137,16	63702	63712	
38	76	140,97	63802	63812	
39	78	144,78	63902	63912	
40	80	148,59	64002	64012	
41	82	152,40	64102	64112	
42	84	156,21	64202	64212	
43	86	160,02	64302	64312	
44	88	163,83	64402	64412	
45	90	167,64	64502	64512	

Note

In view of the use of mounting brackets, all connectors given in the table can also be supplied without contacts at the ends. For ordering these versions, replace last digit of the catalogue number by 4.

MOUNTING

Mounting brackets

Two types of brackets for rail or panel mounting are available:

- thermoplastic bracket, catalogue number 4332 026 06560 (Figs 3 and 4);
- cadmium plated steel bracket, catalogue number 4332 026 06540 (Figs 5 and 6).

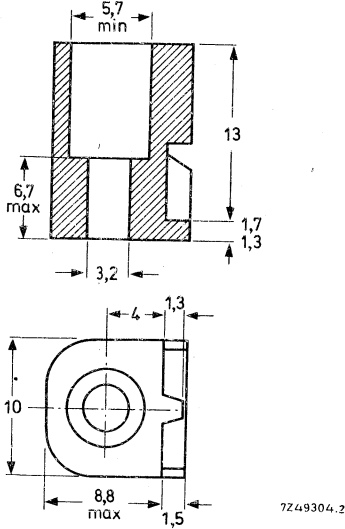

Fig. 3 Thermoplastic mounting bracket
4332 026 06560.

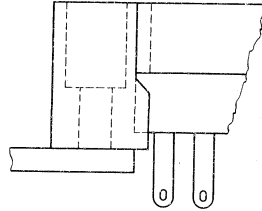

Fig. 4 Part view, showing mounting bracket in position.

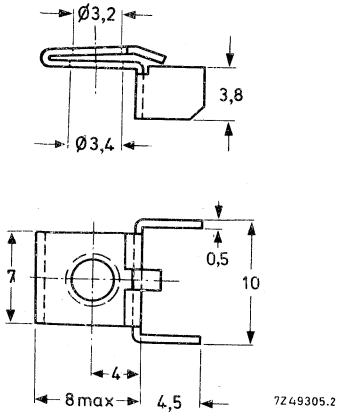

Fig. 5 Cadmium plated steel mounting bracket
4332 026 06540.

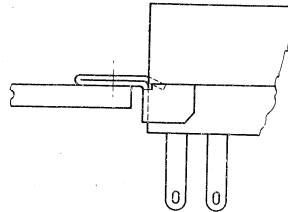

Fig. 6 Part view, showing mounting bracket in position.

Piercing diagrams

In Figs 7 and 8, piercing diagrams are given for connectors with mounting brackets as shown in Figs 3 and 5.

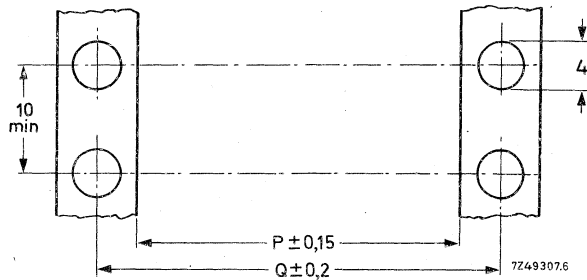

Fig. 7 Piercing diagram for rail mounting; $P = L_{\max} + 7$ mm, $Q = L_{\text{nom}} + 13,4$ mm. For L_{nom} and L_{\max} see Table 1.

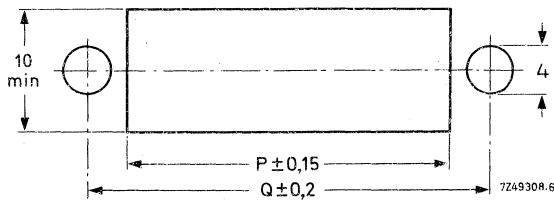

Fig. 8 Piercing diagram for panel mounting; $P = L_{\max} + 7$ mm, $Q = L_{\text{nom}} + 13,4$ mm. For L_{nom} and L_{\max} see Table 1.

Printed-wiring board recommendations

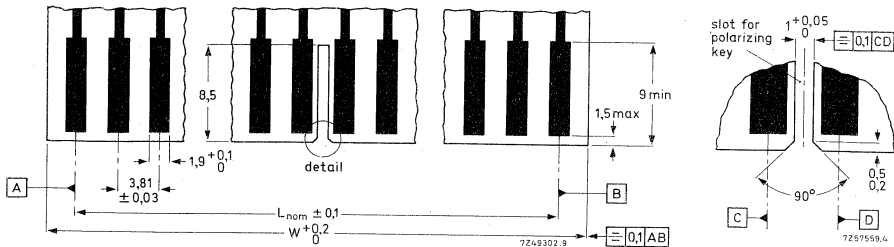

Fig. 9 Recommended dimensions of the printed-wiring board; $W = L_{nom} + 2,6$ mm. For L_{nom} see Table 1.

POLARIZATION AND POSITIONING

A thermoplastic key (Fig. 10) inserted in a slot between any two adjacent contacts ensures that a printed-wiring board is correctly polarized in its connector. This method involves no loss of contacts. A slot must be made in the printed-wiring board to receive the key (Fig. 9).

The same key is also recommended for positioning to avoid misalignment arising from cumulative tolerances in the case of long connectors (with more than 35 contacts, single row), and open-end mounting. For long connectors the slot in the printed-wiring board should be near the centre.

Positioning is not required if a connector with no more than 35 contacts (single row) is used together with thermoplastic brackets.

Catalogue number of polarizing key: 4332 026 06550.

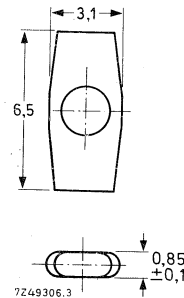

Fig. 10 Polarizing key.

MARKING

The package is marked with:

- 12-digit catalogue number;
- reference number of manufacturer;
- number of pieces.

PRINTED-WIRING CONNECTORS

- For basic grid of 3,96 mm (0,156 in)

QUICK REFERENCE DATA

Contact pitch	3,96 mm (0,156 in)
Number of contacts single row double row	6, 10, 15, 18 and 22 12, 20, 30, 36 and 44
Board thickness	1, 42 to 1,78 mm
Terminations	solder tags
Current at $T_{amb} = 20\text{ }^{\circ}\text{C}$	5,5 A
Mechanical endurance	250 insertions
Climatic category (IEC 68)	65/125/21
Basic specification	MIL-STD-C-21097-1

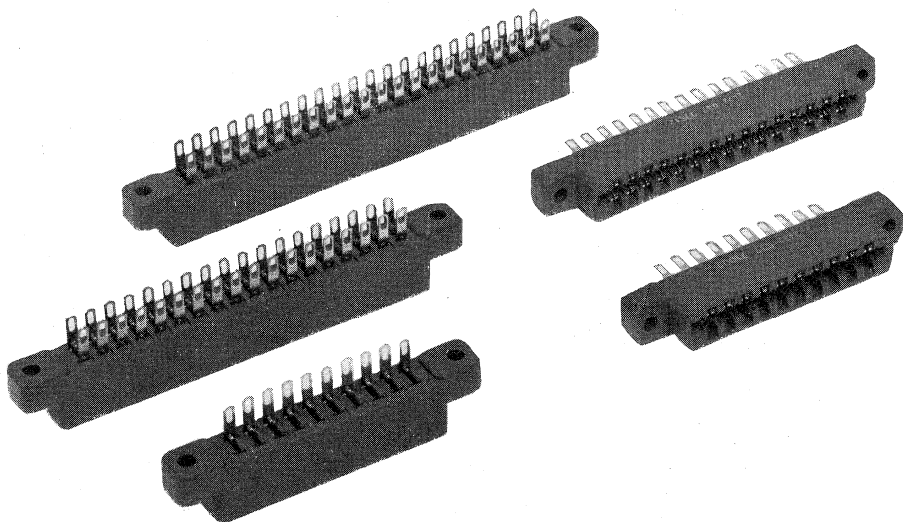

APPLICATION

For use in professional and industrial equipment.

DESCRIPTION

The connectors have a moulded body of a blue tropic-proof glass-fibre-filled thermosetting material. The contact springs are of phosphor bronze, they are bifurcated to provide a double contact. The contact surfaces are gold plate on nickel plate on copper plate.

ELECTRICAL DATA

Current at $T_{amb} = 20^{\circ}\text{C}$

5,5 A

Derated current curve

according to IEC512-3,
test 5b, see Fig. 1

Contact resistance (including material resistance) at 10 mA, max. 20 mV (peak) open circuit voltage, 1 kHz.

Measured outside the body:

initially

$\leq 7 \text{ m}\Omega$

after mechanical endurance

$\leq 7 \text{ m}\Omega$

after damp heat test

$\leq 7 \text{ m}\Omega$

Insulation resistance

initially

$> 10^5 \text{ M}\Omega$

after damp heat test

$> 10^3 \text{ M}\Omega$

Creepage distance between contacts

$\geq 1,9 \text{ mm}$

Clearance between contacts

$\geq 0,4 \text{ mm}$

Proof voltage for 1 min, at 20°C

between adjacent contacts

1000 V (r.m.s.), 50 Hz

between a contact and earth

1000 V (r.m.s.), 50 Hz

Capacitance between contacts at 1 kHz

$\leq 2 \text{ pF}$

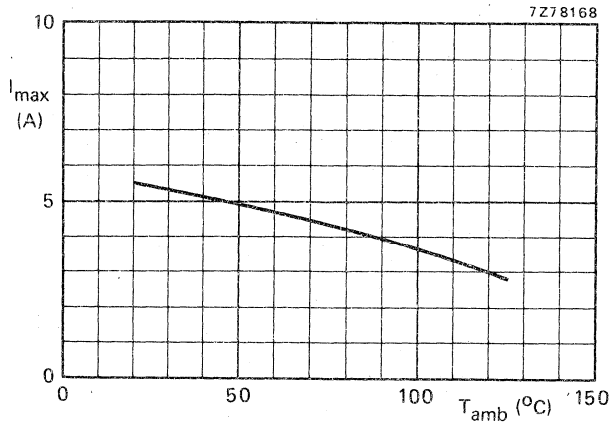

Fig. 1 Maximum current per contact, equally on all contacts, as a function of ambient temperature (20% derated).

MECHANICAL DATA

Contact pitch	3,96 mm (0,156 in)
Number of contacts	6, 10, 15, 18, 22
single row	12, 20, 30, 36, 44
double row	
Board thickness	1,42 to 1,78 mm
Polarization	by means of a polarizing key (see Fig. 5)
Insertion force*	see Table 1
Withdrawal force per contact*	> 0,2 N
Mechanical endurance	250 insertions
Connector body material	glass-fibre-filled thermosetting
Contacts	
material	phosphor bronze
shape	bifurcated
finish of contact surfaces	≥ 1,3 μm gold plate on ≥ 5 μm nickel plate on ≥ 3 μm copper plate
contact force	> 0,8 N
type of termination	solder tag with eyelet
finish of termination	gold flash
Mass	see Table 1
Solderability	235 °C, 2 s
Resistance to soldering heat	350 °C, 10 s
Shock	according to IEC 68, test Ea, 50g, 11 ms
Vibration	according to IEC 68, test Fc, 10 to 2000 Hz, 0,75 mm (p-p) or 10g, 3 directions, 6 h per direction

Table 1

number of contacts	insertion force (N)	approx. mass (g)
12	≤ 27	7
20	≤ 45	10
30	≤ 60	14
36	≤ 70	17
44	≤ 80	20

ENVIRONMENTAL DATA

Climatic category (IEC 68)	65/125/21
Ambient temperature range	-65 to + 125 °C
Damp heat, steady state	according to IEC 68, test Ca, 21 days, 40 °C, R.H. 90 to 95%
Salt mist	according to IEC 68, test Ka, 24 h
Flammability	according to UL94, category V0

* Measured with mechanical gauge according to MIL-STD-C-21097-1.

DIMENSIONAL DATA

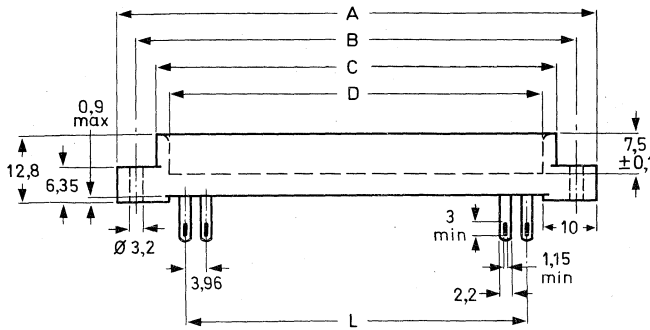

Dimensions in mm

Fig. 2a Double row connector; see Table 2 for dimensions A, B, C, D and L. For the single-row version, one row of contacts is omitted.

Fig. 2b Double-row connector with bridged opposite contacts. Dimensions are identical with those in Fig. 2a except for the tag length; see also Table 2.

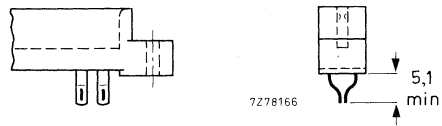

Table 2

number of contacts		dimensions					catalogue number 2422 037				
single row	double row	A _{max}	B	C _{max}	D	L	single row	double row	double-row bridged		
6	12	47,34	38,91	± 0,2	27,94 ± 0,15	19,80	+ 0,2 - 0,1	70602	70612	70616	
10	20	63,19	54,76		48,43	43,79 ± 0,15		35,64	71002	71012	71016
15	30	83,00	74,62		68,27	63,60 ± 0,15		55,44	71502	71512	71516
18	36	94,89	86,51		80,18	75,49 ± 0,15		67,32	71802	71812	71816
22	44	110,74	102,41		96,06	91,34 ± 0,20		83,16	72202	72212	72216

MOUNTING

Dimensions in mm

Panel cut-out

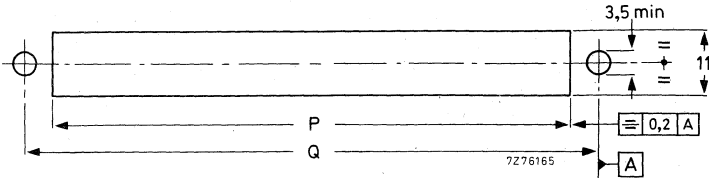

Fig. 3 Panel cut-out; see Table 3 for dimensions P and Q.

Table 3

number of contacts		dimensions	
single row	double row	P	Q
6	12	28,85	38,91
10	20	44,70	54,76
15	30	64,50	74,62
18	36	76,40	86,51
22	44	92,20	102,41
		± 0,2	

Printed-wiring board recommendations

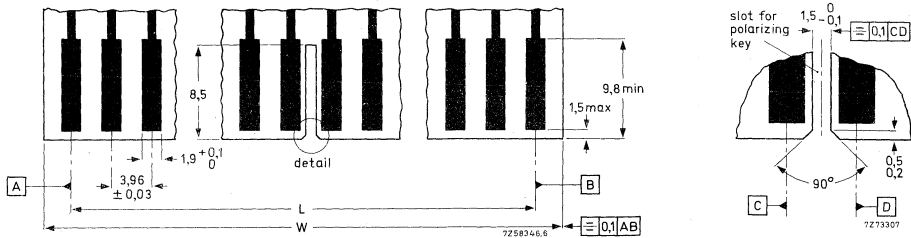

Fig. 4 Recommended dimensions of the printed-wiring board; see Table 4 for dimensions L and W.

Table 4

number of contacts		dimensions	
single row	double row	L	W
6	12	19,80	27,78
10	20	35,64	43,63
15	30	55,44	63,44
18	36	67,32	75,33
22	44	83,16	91,13
		± 0,1	
		-0,2	

POLARIZATION

A thermoplastic key (Fig. 5), inserted in a slot between any two adjacent contacts ensures that a printed-wiring board is correctly polarized in its connector.

This method involves no loss of contacts. A slot must be made in the printed-wiring board to receive the key (Fig. 4).

Catalogue number of polarizing key: 4332 026 06550.

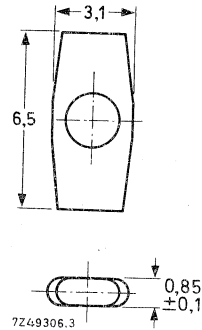

Fig. 5 Polarizing key.

MARKING

Package

The package is marked with:
 12-digit catalogue number;
 reference number of manufacturer;
 number of pieces.

Connector

The body is marked with the 12-digit catalogue number.

The terminations are marked with figures and letters according to MIL-STD-C-21097-1 (Figs 6a and 6b).

Fig. 6a Marking of single row connector with 22 contacts.

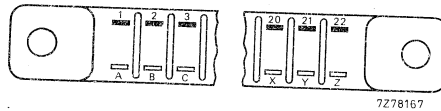
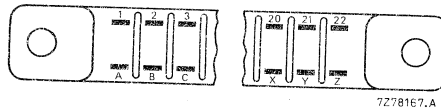

Fig. 6b Marking of double row connector with 44 contacts.



PRINTED-WIRING CONNECTORS

- For basic grid of 3,96 mm (0,156 in)

QUICK REFERENCE DATA

Contact pitch	3,96 mm (0,156 in)
Number of contacts	6, 10, 15, 18 and 22
single row	12, 20, 30, 36 and 44
double row	
Board thickness	1,42 to 1,78 mm
Terminations	solder tags
Current at $T_{amb} = 20^{\circ}C$	5,5 A
Mechanical endurance	100 insertions
Climatic category (IEC 68)	65/125/21

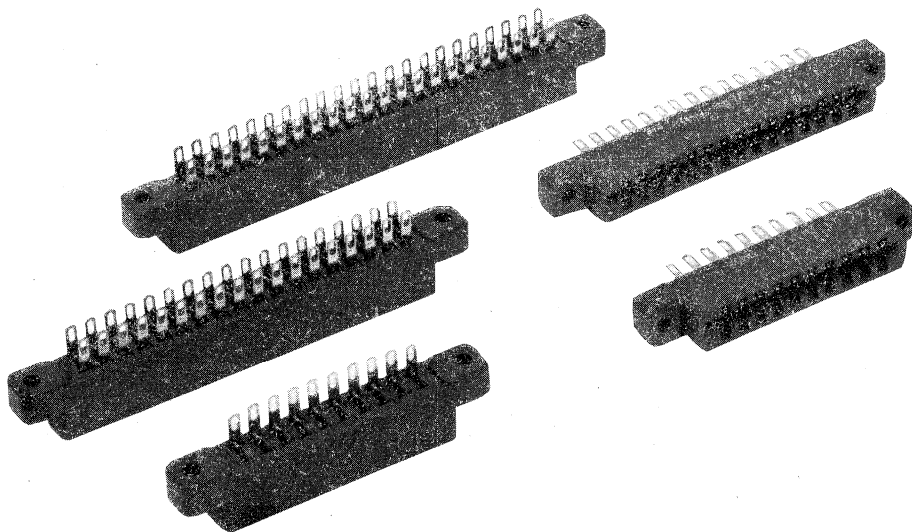

APPLICATION

For use in professional and industrial equipment.

DESCRIPTION

The connectors have a moulded body of a green, tropic-proof glass-fibre-filled thermosetting material. The contact springs are phosphor bronze, they are bifurcated to provide a double contact. The contact surfaces are gold plate on nickel plate.

ELECTRICAL DATA

Current at $T_{amb} = 20\text{ }^{\circ}\text{C}$	5,5 A
Derated current curve	according to IEC512-3, test 5b; see Fig. 1
Contact resistance (including material resistance) at 10 mA, max. 20 mV (peak) open circuit voltage, 1 kHz. Measured outside the body:	
initially	$\leq 10\text{ m}\Omega$
after mechanical endurance	$\leq 10\text{ m}\Omega$
after damp heat test	$\leq 12\text{ m}\Omega$
Insulation resistance	
initially	$> 10^5\text{ M}\Omega$
after damp heat test	$> 10^3\text{ M}\Omega$
Creepage distance between contacts	$\geq 1,9\text{ mm}$
Clearance between contacts	$\geq 0,4\text{ mm}$
Proof voltage for 1 min, at $20\text{ }^{\circ}\text{C}$	
between adjacent contacts	1000 V (r.m.s.), 50 Hz
between a contact and earth	1000 V (r.m.s.), 50 Hz
Capacitance between contacts at 1 kHz	$\leq 2\text{ pF}$

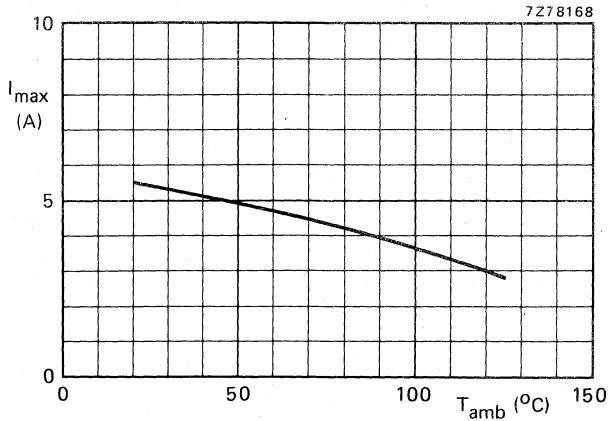

Fig. 1 Maximum current per contact, equally on all contacts, as a function of ambient temperature (20% derated).

MECHANICAL DATA

Contact pitch	3,96 mm (0,156 in)
Number of contacts	6, 10, 15, 18, 22
single row	12, 20, 30, 36, 44
double row	
Board thickness	1,42 to 1,78 mm
Polarization	by means of a polarizing key (see Fig. 5)
Insertion force, measured with mechanical gauge, 1,57 mm	see Table 1
Withdrawal force per contact, measured with mechanical gauge, 1,37 mm	> 0,2 N
Mechanical endurance	100 insertions
Connector body material	glass-fibre-filled thermosetting
Contacts	
material	phosphor bronze
shape	bifurcated
finish of contact surfaces	≥ 0,2 μm gold plate on ≥ 3 μm nickel plate
contact force	> 0,8 N
type of termination	solder tag with eyelet
finish of termination	gold flash
Mass	see Table 1
Solderability	235 °C, 2 s
Resistance to soldering heat	350 °C, 10 s
Shock	according to IEC 68, test Ea, 50g, 11 ms
Vibration	according to IEC 68, test Fc, 10 to 2000 Hz, 0,75 mm (p-p) or 10g, 3 directions, 6 h per direction

Table 1

number of contacts	insertion force (N)	approx. mass (g)
12	≤ 27	7
20	≤ 45	10
30	≤ 60	14
36	≤ 70	17
44	≤ 80	20

ENVIRONMENTAL DATA

Climatic category (IEC 68)	65/125/21
Ambient temperature range	-65 to + 125 °C
Damp heat, steady state	according to IEC 68, test Ca, 21 days, 40 °C, R.H. 90 to 95%
Flammability	according to UL94, category V0

DIMENSIONAL DATA

Dimensions in mm

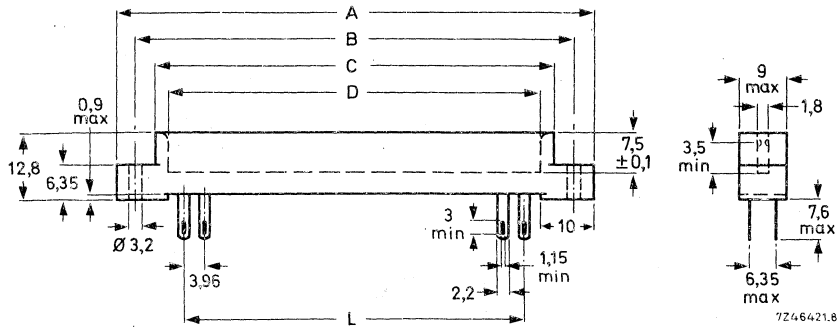

Fig. 2a Double row connector; see Table 2 for dimensions A, B, C, D and L. For the single-row version, one row of contacts is omitted.

Fig. 2b Double-row connector with bridged opposite contacts. Dimensions are identical with those in Fig. 2a except for the tag length; see also Table 2.

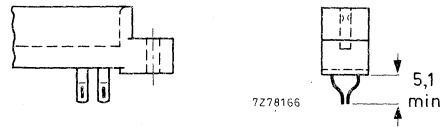

Table 2

number of contacts		dimensions					catalogue number 2422 037			
single row	double row	A _{max}	B	C _{max}	D	L	single row	double row	double-row bridged	
6	12	47,34	38,91	± 0,2	32,56	27,94 ± 0,15	19,80	00602	00612	00616
10	20	63,19	54,76		48,43	43,79 ± 0,15	35,64	01002	01012	01016
15	30	83,00	74,62		68,27	63,60 ± 0,15	55,44	01502	01512	01516
18	36	94,89	86,51		80,18	75,49 ± 0,15	67,32	01802	01812	01816
22	44	110,74	102,41		96,06	91,34 ± 0,20	83,16	02202	02212	02216

MOUNTING

Dimensions in mm

Panel cut-out

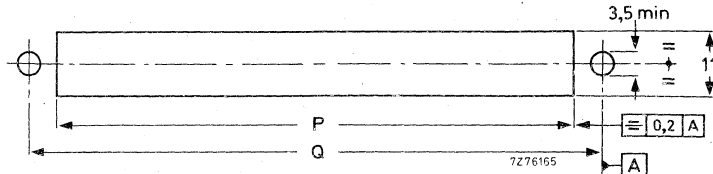

Fig. 3 Panel cut-out; see Table 3 for dimensions P and Q.

Table 3

number of contacts		dimensions	
single row	double row	P	Q
6	12	28,85	38,91
10	20	44,70	54,76
15	30	64,50	74,62
18	36	76,40	86,51
22	44	92,20	102,41

} ± 0,2

Printed-wiring board recommendations

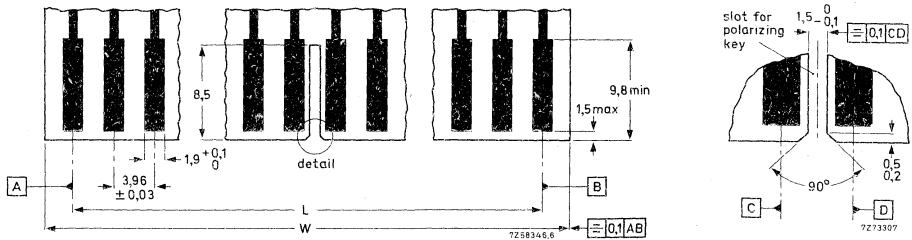

Fig. 4 Recommended dimensions of the printed-wiring board; see Table 4 for dimensions L and W.

Table 4

number of contacts		dimensions	
single row	double row	L	W
6	12	19,80	27,78
10	20	35,64	43,63
15	30	55,44	63,44
18	36	67,32	75,33
22	44	83,16	91,13

} ± 0,1

} -0,2

POLARIZATION

A thermoplastic key (Fig. 5), inserted in a slot between any two adjacent contacts ensures that a printed-wiring board is correctly polarized in its connector.

This method involves no loss of contacts. A slot must be made in the printed-wiring board to receive the key (Fig. 4).

Catalogue number of polarizing key: 4332 026 06550.

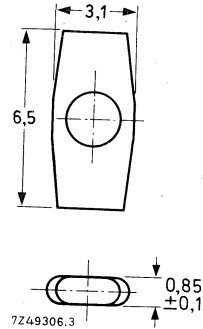

Fig. 5 Polarizing key.

MARKING

Package

The package is marked with:
 12-digit catalogue number;
 reference number of manufacturer;
 number of pieces.

Connector

The body is marked with the 12-digit catalogue number.
 The terminations are marked with figures and letters (Figs 6a and 6b).

Fig. 6a Marking of single row connector with 22 contacts.

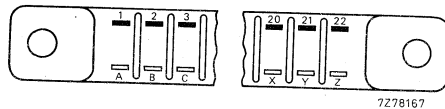
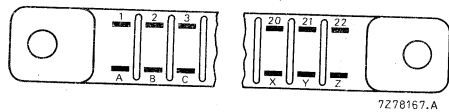

Fig. 6b Marking of double row connector with 44 contacts.



PRINTED-WIRING INTERCONNECTORS

- 3,96 mm (0,156 in) pitch

QUICK REFERENCE DATA

Contact pitch	3,96 mm (0,156 in)
Number of contacts	6, 10 15, 18 and 22
single row	12, 20, 30, 36 and 44
double row	
Board thickness	1,42 to 1,78 mm
Terminations	solder tags
Current at $T_{amb} = 20\text{ }^{\circ}\text{C}$	5,5 A
Mechanical endurance	300 insertions
Climatic category (IEC 68)	65/125/21

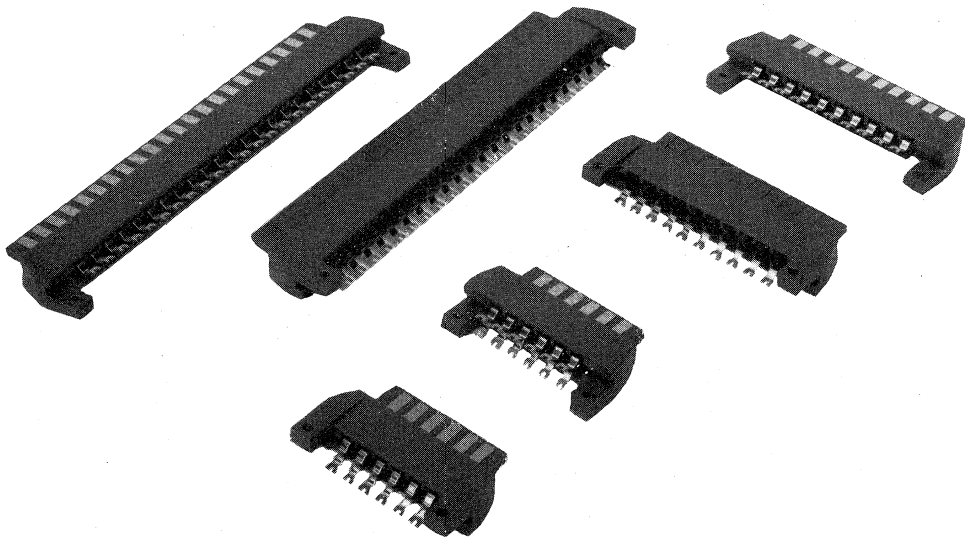

APPLICATION

For use in professional and industrial equipment.

DESCRIPTION

The interconnectors have a body of green glass-fibre-filled thermosetting material. The contact springs are of phosphor bronze. The contact surfaces are rolled gold on nickel plate.

The interconnectors mate with the printed-wiring connectors F050 and F053.

ELECTRICAL DATA

Current at $T_{amb} = 20\text{ }^{\circ}\text{C}$	5,5 A
Derated current curve	according to IEC 512-3, test 5b, see Fig. 1
<p>Contact resistance (including material resistance) at 10 mA, max. 20 mV (peak) open circuit voltage, 1 kHz.</p> <p>Measured outside the body:</p> <p> initially $\leq 8\text{ m}\Omega$</p> <p> after mechanical endurance $\leq 8\text{ m}\Omega$</p> <p> after damp heat test $\leq 10\text{ m}\Omega$</p>	
<p>Insulation resistance</p> <p> initially $> 10^5\text{ M}\Omega$</p> <p> after damp heat test $> 10^3\text{ M}\Omega$</p>	
Creepage distance between contacts	$\geq 1,25\text{ mm}$
Clearance between contacts	$\geq 1,25\text{ mm}$
<p>Proof voltage for 1 min at $20\text{ }^{\circ}\text{C}$</p> <p> between adjacent contacts</p>	1000 V (r.m.s.), 50 Hz
<p>Capacitance</p> <p> between adjacent contacts $\leq 1,5\text{ pF}$</p> <p> between opposite contacts $\leq 2\text{ pF}$</p>	

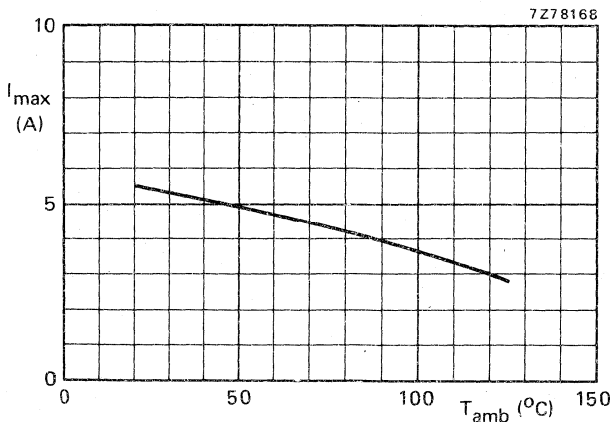

Fig. 1 Maximum current per contact, equally on all contacts, as a function of ambient temperature (20% derated).

MECHANICAL DATA

Contact pitch	3,96 mm (0,156 in)
Number of contacts	6, 10, 15, 18, 22
single row	12, 20, 30, 36, 44
double row	1,42 to 1,78 mm
Board thickness	300 insertions
Mechanical endurance	glass-fibre-filled thermosetting
Connector body material	
Contacts	
material	phosphor bronze
shape	single face
finish of contact surfaces	$\geq 3 \mu\text{m}$ rolled gold
type of termination	solder tag with open eyelet
finish of termination	gold flash
Mass	see Table 1
Solderability	235 °C, 2 s } according to
Resistance to soldering heat	350 °C, 10 s } IEC 68, test T
Shock	according to IEC 68, test Ea, 50g, 11 ms
Vibration	according to IEC 68, test Fc, 10 to 2000 Hz, 0,75 mm (p-p) or 10g, 3 directions, 6 h per direction

Table 1

number of contacts	approx. mass (g)
12	6
20	8
30	11
36	12
44	15

ENVIRONMENTAL DATA

Climatic category (IEC 68)	65/125/21
Ambient temperature range	-65 to +125 °C
Damp heat, steady state	according to IEC 68, test Ca, 21 days, 40 °C, R.H. 90 to 95%
Flammability	according to UL 94, category V0

DIMENSIONAL DATA

Dimensions in mm

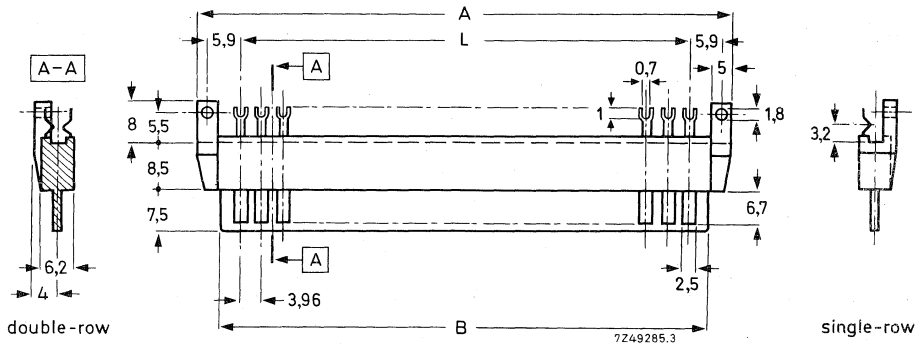

Fig. 2 Printed-wiring interconnector; see Table 2 for dimensions A, B and L.

Table 2

number of contacts		dimensions (mm)			catalogue number	
single row	double row	A max.	B	L	single row	double row
6	12	37,45	27,74	19,80 $\begin{matrix} +0,15 \\ -0,1 \end{matrix}$	2422 025 89071	2422 025 89076
10	20	53,34	43,58	35,64	89072	89077
15	30	73,14	63,40	55,44 $\begin{matrix} +0,2 \\ -0,1 \end{matrix}$	89073	89078
18	36	85,02	75,30	67,32	89074	89079
22	44	100,86	91,10	83,16	89075	89081

MOUNTING

Printed-wiring board recommendations

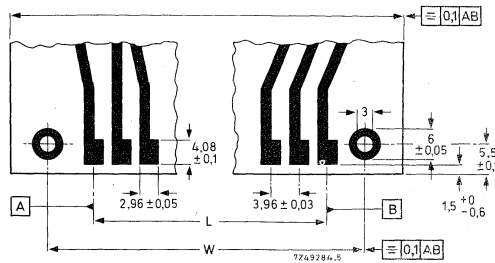

Fig. 3 Recommended dimensions of the printed-wiring board; see Table 3 for dimensions L and W.

Table 3

number of contacts		dimensions (mm)	
single row	double row	L	W
6	12	19,80	31,68
10	20	35,64	47,52
15	30	55,44	67,32
18	36	67,32	79,20
22	44	83,16	95,04

The interconnector should be fixed to the printed-wiring board by means of screws or tubular rivets (max. $\phi 1,7$ mm), after positioning the board in such a way that the solder tags are opposite the corresponding contact pads of the board. To improve the rigidity of the fixing a washer with a diameter of 4,5 mm and a hole of $1,8 \pm 0,1$ mm should be placed under the screw or rivet and soldered to the copper isle of the mounting hole. See also Fig. 4. The solder tags should then be soldered to the contact pads.

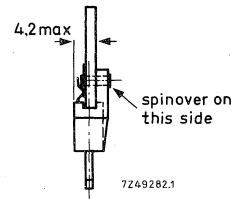

Fig. 4 Fixing of the interconnector to the printed-wiring board.

MARKING

The package is marked with:
 12-digit catalogue number;
 reference number of manufacturer;
 number of pieces.

PRINTED-WIRING CONNECTORS

- For basic grid of 3,96 mm (0,156 in)

QUICK REFERENCE DATA

Contact pitch	3,96 mm (0,156 in)
Number of contacts	
single row	6, 10, 15, 18, 22, 28, 36 and 43
double row	12, 20, 30, 36, 44, 56, 72 and 86
Board thickness	1,42 to 1,78 mm
Terminations	dip-solder pins pins for wire wrapping
Current at $T_{amb} = 20\text{ }^{\circ}\text{C}$	4 A
Mechanical endurance	250 insertions
Climatic category (IEC 68)	40/125/21

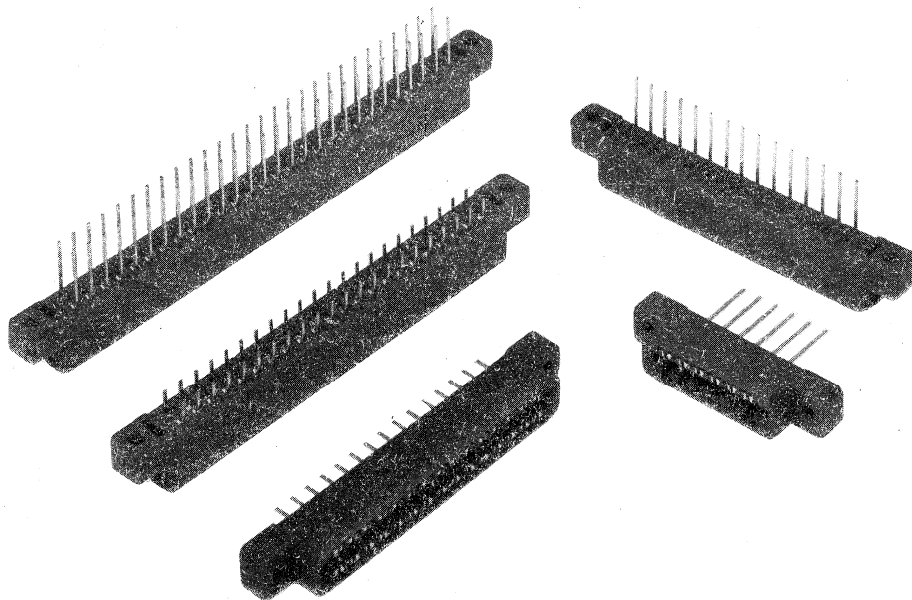

APPLICATION

For use in professional and industrial equipment.

DESCRIPTION

The connectors have a moulded body of a red tropic-proof glass-fibre-filled thermoplastic material. The contact springs are of phosphor bronze, they are bifurcated to provide a double contact. The contact surfaces are gold plate on nickel plate.

ELECTRICAL DATA

Current at $T_{amb} = 20\text{ }^{\circ}\text{C}$

4 A

Derated current curve

according to IEC 512-3,
test 5b; see Fig. 1

Contact resistance (including material resistance) at 10 mA,
max. 20 mV (peak) open circuit voltage, 1 kHz.

Measured outside the body:

initially

$\leq 18\text{ m}\Omega$

after mechanical endurance

$\leq 18\text{ m}\Omega$

after damp heat test

$\leq 20\text{ m}\Omega$

Insulation resistance

initially

$> 10^5\text{ M}\Omega$

after damp heat test

$> 10^3\text{ M}\Omega$

Creepage distance between contacts

$\geq 2,1\text{ mm}$

Clearance between contacts

$\geq 0,4\text{ mm}$

Proof voltage for 1 min, at $20\text{ }^{\circ}\text{C}$

between adjacent contacts

1000 V (r.m.s.), 50 Hz

between a contact and earth

1000 V (r.m.s.), 50 Hz

Capacitance between contacts at 1 kHz

$\leq 2\text{ pF}$

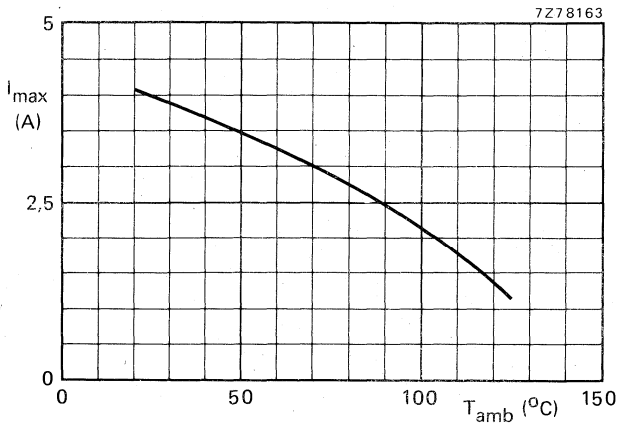

Fig. 1 Maximum current per contact, equally on all contacts, as a function of ambient temperature (20% derated).

MECHANICAL DATA

Contact pitch	3,96 mm (0,156 in)
Number of contacts	6, 10, 15, 18, 22, 28, 36, 43
single row	12, 20, 30, 36, 44, 56, 72, 86
double row	
Board thickness	1,42 to 1,78 mm
Polarization	by means of a polarizing key (see Fig. 6)
Insertion force, measured with mechanical gauge, 1,57 mm	see Table 1
Withdrawal force per contact, measured with mechanical gauge, 1,37 mm	> 0,2 N
Mechanical endurance	250 insertions
Connector body material	glass-fibre-filled thermoplastic
Contacts	
material	phosphor bronze
shape	bifurcated
finish of contact surfaces	≥ 1,3 μm gold plate on ≥ 5 μm nickel plate
contact force	> 0,8 N
type of termination	dip-solder pin; pin for wire wrapping
finish of termination	gold flash
Wire diameter	AWG30 to AWG26 (φ 0,25 to 0,40 mm)
Mass	see Table 1
Solderability	235 °C, 2 s
Resistance to soldering heat	260 °C, 5 s
Shock	according to IEC 68, test T
Vibration	according to IEC 68, test Ea, 50g, 11 ms according to IEC 68, test Fc, 10 to 2000 Hz, 0,75 mm (p-p) or 10g, 3 directions, 6 h per direction

Table 1

number of contacts	insertion force N	approx. mass g
12	≤ 27	7
20	≤ 45	10
30	≤ 60	14
36	≤ 70	17
44	≤ 80	20
56	≤ 100	25
72	≤ 120	31
86	≤ 140	37

ENVIRONMENTAL DATA

Climatic category (IEC 68)	40/125/21
Ambient temperature range	-40 to + 125 °C
Damp heat, steady state	according to IEC 68, test Ca, 21 days, 40 °C, R.H. 90 to 95%
Flammability	according to UL94, category V1

DIMENSIONAL DATA

Dimensions in mm

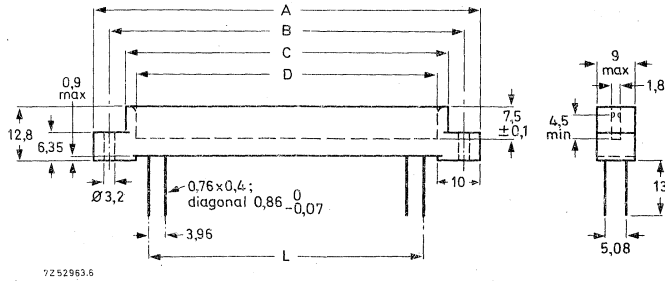

Fig. 2a Double row connector with pins for wire wrapping; see Table 2 for dimensions A, B, C, D and L. For the single-row version, one row of contacts is omitted.

Fig. 2b Double row connector with dip-solder pins. Dimensions are identical to those in Fig. 2a, except for the pin length; see also Table 3. For the single-row version, one row of contacts is omitted.

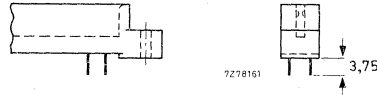

Table 2 Connectors with pins for wire wrapping

number of contacts		dimensions					catalogue number 2422 039		
single row	double row	A _{max}	B	C _{max}	D	L	single row	double row	
6	12	47,34	38,91 ± 0,2	32,56	27,94 ± 0,15	19,80	+ 0,2 - 0,1	00602	00612
10	20	63,19	54,76 ± 0,2	48,43	43,79 ± 0,15	35,64		01002	01012
15	30	83,00	74,62 ± 0,2	68,27	63,60 ± 0,15	55,44		01502	01512
18	36	94,89	86,51 ± 0,2	80,18	75,49 ± 0,15	67,32		01802	01812
22	44	110,74	102,41 ± 0,2	96,06	91,34 ± 0,20	83,16		02202	02212
28	56	134,21	126,09 ± 0,4	118,97	115,11 ± 0,25	106,92		02802	02812
36	72	166,19	157,99 ± 0,4	150,67	146,76 ± 0,25	138,60		03602	03612
43	86	193,82	185,47 ± 0,4	178,61	174,55 ± 0,25	166,32	04302	04312	

Table 3 Connectors with dip-solder pins

number of contacts		dimensions					catalogue number 2422 044		
single row	double row	A _{max}	B	C _{max}	D	L	single row	double row	
6	12	47,34	38,91 ± 0,2	32,56	27,94 ± 0,15	19,80	} +0,2 -0,1	00602	00612
10	20	63,19	54,76 ± 0,2	48,43	43,79 ± 0,15	35,64		01002	01012
15	30	83,00	74,62 ± 0,2	68,27	63,60 ± 0,15	55,44		01502	01512
18	36	94,89	86,51 ± 0,2	80,18	75,49 ± 0,15	67,32		01802	01812
22	44	110,74	102,41 ± 0,2	96,06	91,34 ± 0,20	83,16		02202	02212
28	56	134,21	126,09 ± 0,4	118,97	115,11 ± 0,25	106,92		02802	02812
36	72	166,19	157,99 ± 0,4	150,67	146,76 ± 0,25	138,60		03602	03612
43	86	193,82	185,47 ± 0,4	178,61	174,55 ± 0,25	166,32		04302	04312

MOUNTING

Dimensions in mm

Panel cut-out

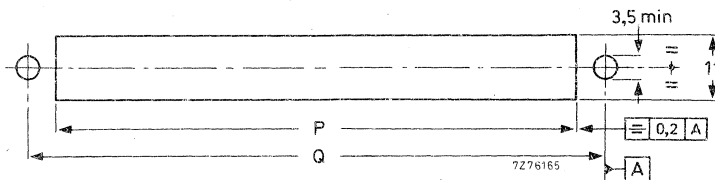

Fig. 3 Panel cut-out; see Table 4 for dimensions P and Q.

Table 4

number of contacts		dimensions	
single row	double row	P	Q
6	12	28,85	38,91
10	20	44,70	54,76
15	30	64,50	74,62
18	36	76,40	86,51
22	44	92,20	102,41
28	56	115,70	126,09
36	72	147,70	157,99
43	86	175,30	185,47

Table 6

number of contacts		dimensions	
single row	double row	L	W
6	12	19,80	27,78
10	20	35,64	43,63
15	30	55,44	63,44
18	36	67,32	75,33
22	44	83,16	91,13
28	56	106,92	114,85
36	72	138,60	146,50
43	86	166,32	174,29

POLARIZATION

A thermoplastic key (Fig. 6), inserted in a slot between any two adjacent contacts ensures that a printed-wiring board is correctly polarized in its connector. This method involves no loss of contacts. A slot must be made in the printed-wiring board to receive the key (Fig. 5).

Catalogue number of polarizing key: 4332 026 06550.

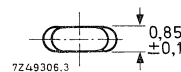
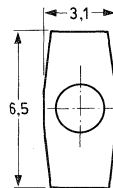

Fig. 6 Polarizing key.

MARKING

Package

The package is marked with:

- 12-digit catalogue number;
- reference number of manufacturer;
- number of pieces.

Connector

The terminations are marked with figures and letters (Figs 7a and 7b).

Fig. 7a Marking of single-row connector with 22 contacts.

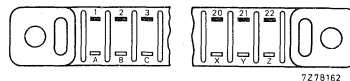
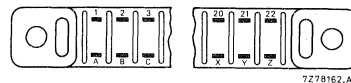

Fig. 7b Marking of double-row connector with 44 contacts.



TWO-PART PRINTED-WIRING CONNECTORS

- For basic grid of 2,54 mm (0,1 in).

QUICK REFERENCE DATA

Contact pitch	2,54 mm (0,1 in)
Number of contacts	32, 48, 64
Board thickness	1,42 to 1,78 mm.
Terminations	solder tags
male part	straight dip-solder pins
	pins for wire wrapping
female part	90° angled dip-solder pins
Current at $T_{amb} = 20\text{ }^{\circ}\text{C}$	3,5 A
Mechanical endurance	300 insertions
Climatic category (IEC 68)	65/125/21

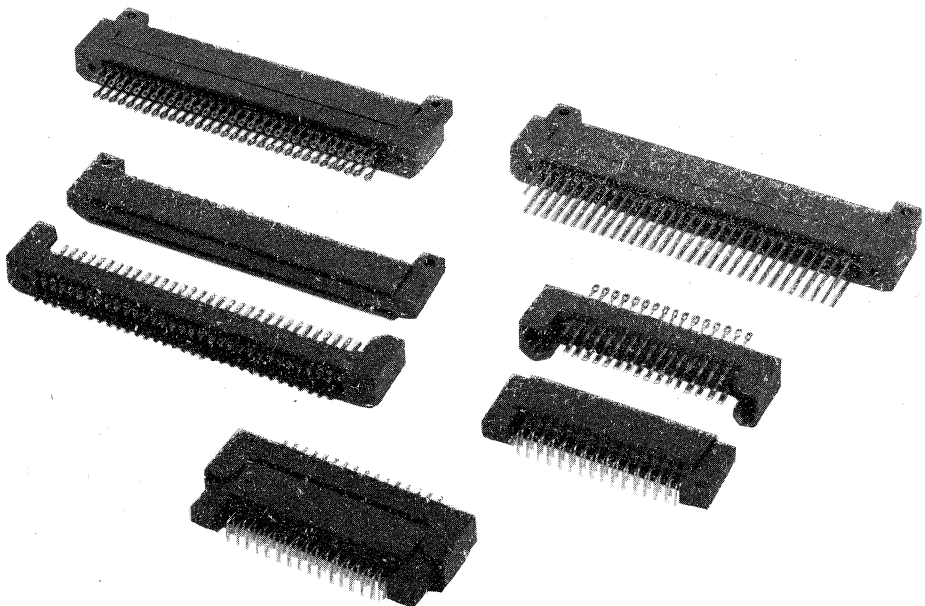

APPLICATION

These connectors are designed for use in applications where high quality and high density packaging of electronic circuits are required.

DESCRIPTION

The connectors consist of a female part to be fitted to a printed-wiring board and a male part to be mounted on a chassis or a back panel. Both parts have a blue body of glass-fibre-filled thermosetting material. The contact springs of the female part and the contact pins of the male part are of phosphor bronze; the contact surfaces are rolled gold on nickel plating. The contact terminations of both parts are gold flashed. No special provisions are required for polarization.

ELECTRICAL DATA

Current at $T_{amb} = 20\text{ }^{\circ}\text{C}$	3,5 A
Derated current curve	according to IEC 512-3, test 5b, see Fig. 1
Contact resistance (including material resistance) at 10 mA, max. 20 mV (peak) open circuit voltage, 1 kHz	
initially	$\leq 17\text{ m}\Omega$
after mechanical endurance	$\leq 20\text{ m}\Omega$
after damp heat test (IEC 68, test Ca)	$\leq 20\text{ m}\Omega$
Insulation resistance	
initially	$> 10^5\text{ M}\Omega$
after damp heat test (IEC 68, test Ca)	$> 10^3\text{ M}\Omega$
Creepage distance between contacts	$\geq 0,8\text{ mm}$
Clearance between contacts	$\geq 0,8\text{ mm}$
Proof voltage for 1 min, at $20\text{ }^{\circ}\text{C}$	
between adjacent contacts	1000 V (r.m.s.), 50 Hz
between a contact and earth	2000 V (r.m.s.), 50 Hz
Capacitance between contacts at 1 kHz	$\leq 2\text{ pF}$

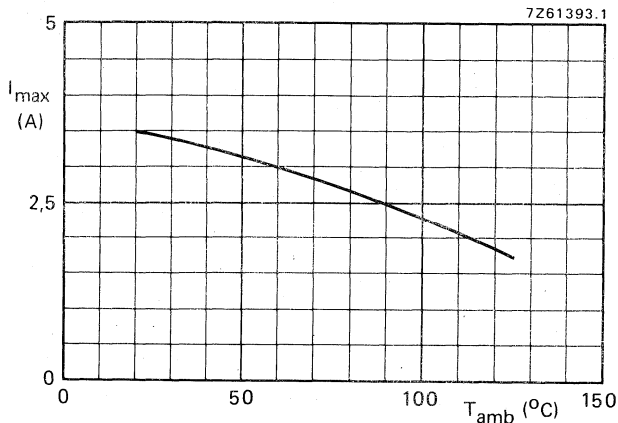

Fig. 1 Maximum current per contact, equally on all contacts, as a function of ambient temperature (20% derated).

MECHANICAL DATA

Contact pitch	2,54 mm (0,1 in)
Number of contacts	32, 48, 64
Board thickness	1,42 to 1,78 mm
Polarization	achieved by asymmetrical housing
Insertion force and withdrawal force	see Table 1
Mechanical endurance	300 insertions
Connector body material	glass-fibre-filled thermosetting
Contacts	
material	male part phosphor bronze
shape	rectangular pin single face
finish of contact surfaces	≥ 2,5 μm rolled-on ≥ 2,5 μm rolled-on
	gold on ≥ 1 μm gold on ≥ 1 μm
	nickel plate nickel plate
type of termination	solder tag 90° angled dip-solder pin
	straight dip-solder pin pin
	pin for wire wrapping
finish of termination	gold flash gold flash
Wire diameter	AWG30 to AWG26 (φ0,25 to φ0,40 mm)
Mass	see Table 1
Solderability	235 °C, 2 s
Resistance to soldering heat	350 °C, 10 s
Shock	according to IEC 68, test Ea, 50g, 11 ms
Vibration	according to IEC 68, test Fc, 10 to 2000 Hz, 0,75 mm (p-p) or 10g, 3 directions, 6 h per direction

Table 1

number of contacts	insertion force N	withdrawal force N	approx. mass (g)	
			male part	female part
32	≤ 45	≥ 5	10	6
48	≤ 65	≥ 7,5	12	9
64	≤ 85	≥ 10	15	12

ENVIRONMENTAL DATA

Climatic category (IEC 68)	65/125/21
Ambient temperature range	-65 to + 125 °C
Damp heat, steady state	according to IEC 68, test Ca, 21 days, 40 °C, R.H. 90 to 95%
Flammability	according to UL94, category V0

DIMENSIONAL DATA

Dimensions in mm

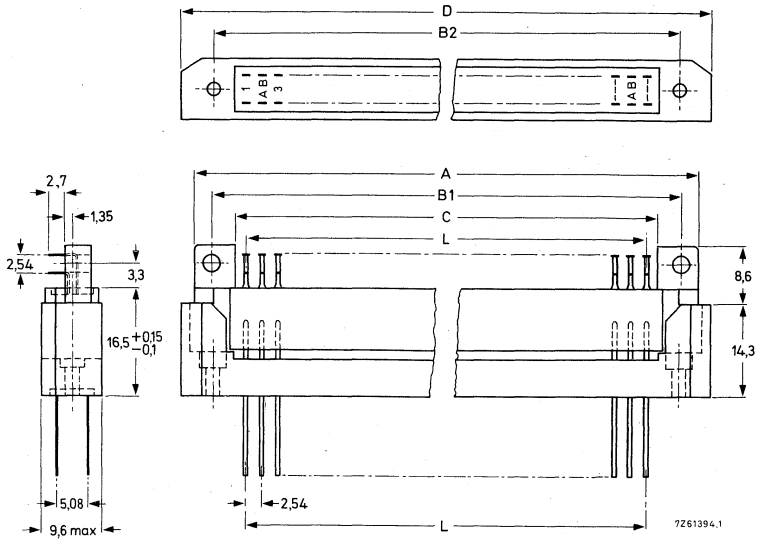

Fig. 2 Connector combination showing female part with 90° angled dip-solder pins and male part with pins for wire wrapping; see Table 2 for dimensions A, B1, B2, C, D and L. See Figs 3, 4 and 5 for different terminations of the male part.

Table 2

number of contacts	dimensions					
	A _{max}	B1	B2	C _{min}	D _{max}	L
32	54,3	48,26	48,26 68,58 88,90	41,4 61,7 82,0	58,3 78,6 98,9	38,10 58,42 78,74
48	74,7	68,58				
64	95,1	88,90				

Male parts

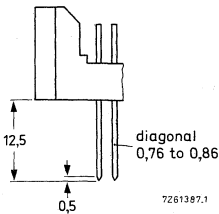

Fig. 3 Pins for wire wrapping.

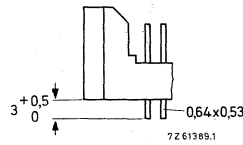

Fig. 4 Straight dip-solder pins.

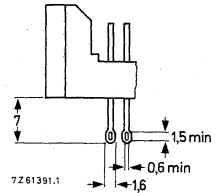

Fig. 5 Solder tags.

Table 3 Catalogue numbers for ordering

number of contacts	catalogue number			
	male part			female part
	pins for wire wrapping (Fig. 3)	dip-solder pins (Fig. 4)	solder tags (Fig. 5)	
32	2422 025 89117	2422 025 89119	2422 025 89121	2422 025 89114
48	89123	89125	89126	89115
64	89128	89131	89132	89116

MOUNTING

Dimensions in mm

Hole patterns for mounting of male parts

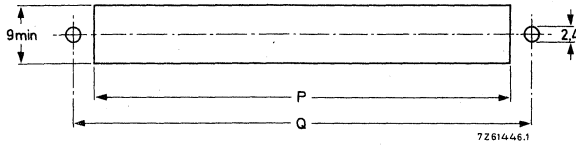

Fig. 6 Hole pattern for panel mounting of male parts; see Table 4 for dimensions P and Q.

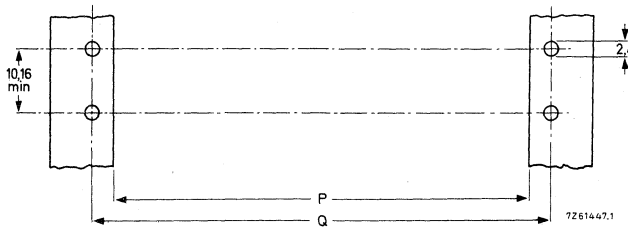

Fig. 7 Hole pattern for rail mounting of male parts; see Table 4 for dimensions P and Q.

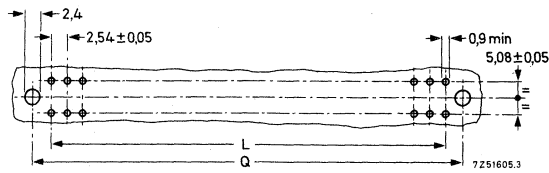

Fig. 8 Hole pattern for board mounting of male parts; see Table 4 for dimensions L and Q.

Hole pattern for mounting of female parts

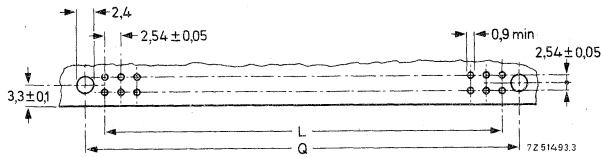

Fig. 9 Hole pattern for board mounting of female parts; see Table 4 for dimensions L and Q.

Table 4

number of contacts	dimensions		
	L	P	Q
32	38,10	43,2	48,26
48	58,42	63,5	68,58
64	78,74	83,8	88,90

} ± 0,05 } ± 0,1 } ± 0,1

POLARIZATION

To ensure that the female part is inserted into the correct male part, it is recommended to use a polarizing key (Fig. 10). This key is inserted into a contact position of the female part. The corresponding contact pin of the male part must be broken off.

Catalogue number of polarizing key: 4332 026 10840.

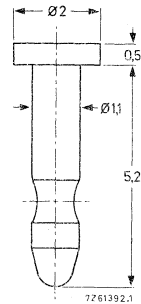

Fig. 10 Polarizing key.

MARKING

Package

The package is marked with:
 12-digit catalogue number;
 reference number of manufacturer;
 number of pieces.

Connector

The terminations of the male part are marked as shown in Fig. 11.

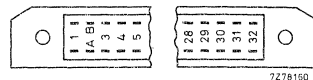

Fig. 11 Marking of male part with 64 contacts.

TWO-PART PRINTED-WIRING CONNECTORS

- For basic grid of 2,54 mm (0,1 in)

QUICK REFERENCE DATA

Contact pitch	2,54 mm (0,1 in)	5,08 mm (0,2 in)
Number of contacts		
style B (2 rows)	32,64	
style C (3 rows)	64,96	32
Board thickness	1,42 to 1,78 mm	
Terminations		
male part	90° angled dip-solder pins straight dip-solder pins solder tags 90° angled pins for wire wrapping	} with or without protruding earth contacts
female part	pins for wire wrapping straight dip-solder pins solder tags 90° angled dip-solder pins	
Current at $T_{amb} = 20\text{ °C}$	2A	
Mechanical endurance		
according to IEC and DIN	400 insertions	
according to VG*	500 insertions	
Climatic category (IEC 68)	55/125/56	
Detail specifications	IEC 130-14, DIN 41612 and VG 95324	

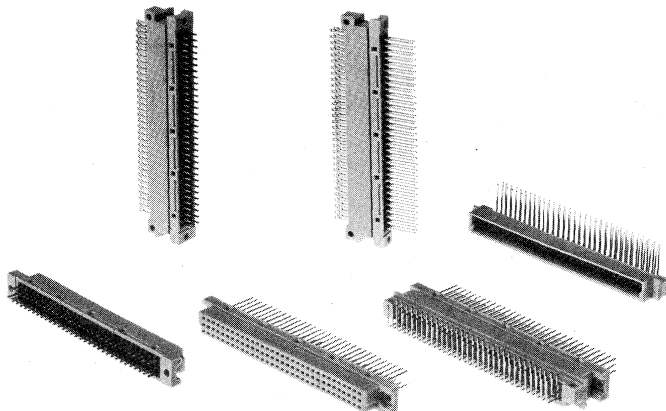

* German military standard.

Contents	page
Application	2
Description	2
Survey	3
Electrical data	4
Mechanical data	5
Environmental data	7
Dimensional data	
style B	8
style C	12
Mounting	16
Marking	20
Accessories	
cable hood	21
coding parts	24
accessories for female parts with pins for wire wrapping	27
mounting brackets for female parts with 90° angled dip-solder pins	28
Packing	30

APPLICATION

These connectors are designed for use in applications where high quality and high density packaging of electronic circuits are required. They can be used on single Eurocards (100 mm x 160 mm), double Eurocards (233,3 mm x 160 mm) and 19-in racks according to DIN 41494.

DESCRIPTION

The connectors consist of a male part to be fitted to a printed-wiring board and a female part to be mounted on a chassis or a back panel. Both parts have a grey body of glass-fibre-filled thermoplastic material; the contact insert of the female part is of glass-fibre-filled diallylphthalate. The contact springs of the female part are of phosphor bronze; the contact pins of the male part are of brass; the contact surfaces are gold on nickel plating. The contact terminations of both parts are gold flashed. The male parts with dip-solder pins can be supplied with protruding earth contacts, which are approximately 1 mm longer than the other contacts. No special provisions are required for polarization. Cable hoods, locking clips and brackets are available for various applications. An external keying system can be employed to ensure correct positioning of the board in a rack.

SURVEY

		style B			style C	
		number of contacts		number of contacts	number of contacts	
		2 x 32	1 x 32	3 x 32	2 x 32	2 x 16
terminations		2,54 mm pitch	2,54 mm pitch	2,54 mm pitch	2,54 mm pitch	5,08 mm pitch
male parts	90° angled dip-solder pins, with or without protruding earth contacts					
	straight dip-solder pins, with or without protruding earth contacts					
	solder tags					
	90° angled pins for wire wrapping					
female parts	pins for wire wrapping					
	straight dip-solder pins					
	solder tags					
	90° angled dip-solder pins					

ELECTRICAL DATA

Current at $T_{amb} = 20\text{ }^{\circ}\text{C}$

Derated current curve

2 A

according to IEC 512-3,
test 5b and VG 95324, part 1

Contact resistance (including material resistance)
at 10 mA, max. 20 mV (peak) open circuit voltage, 1 kHz

- initially $\leq 20\text{ m}\Omega$
- after mechanical endurance $\leq 20\text{ m}\Omega$
- after damp heat test (IEC 68, test Ca) $\leq 20\text{ m}\Omega$

Insulation resistance

- initially $> 10^6\text{ M}\Omega$
- after damp heat test (IEC 68, test Ca) $> 10^4\text{ M}\Omega$
- at maximum ambient temperature $> 10^5\text{ M}\Omega$

Creepage distance

- | | | |
|-----------------------------|------------------------|------------------------|
| | 2,54 mm pitch | 5,08 mm pitch |
| between contacts | $\geq 1,2\text{ mm}$ } | $\geq 3,0\text{ mm}$ } |
| between a contact and earth | $\geq 1,8\text{ mm}$ } | $\geq 1,8\text{ mm}$ } |

Clearance

- | | | |
|-----------------------------|------------------------|------------------------|
| | 2,54 mm pitch | 5,08 mm pitch |
| between contacts | $\geq 1,2\text{ mm}$ } | $\geq 3,0\text{ mm}$ } |
| between a contact and earth | $\geq 1,6\text{ mm}$ } | $\geq 1,6\text{ mm}$ } |

Proof voltage for 1 min, at $20\text{ }^{\circ}\text{C}$

- between contacts 1000 V (r.m.s.), 50 Hz
- between a contact and earth 1550 V (r.m.s.), 50 Hz

Capacitance between contacts at 1 kHz

$\leq 1,5\text{ pF}$

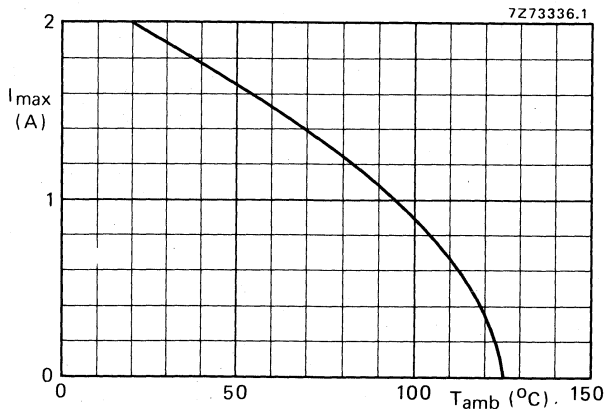

Fig. 1 Maximum current per contact, equally on all contacts, as a function of ambient temperature (20% derated).

* This value may be reduced by the wiring and/or the printed-wiring boards.

MECHANICAL DATA

Contact pitch	2,54 mm (0,1 in)	5,08 mm (0,2 in)
Number of contacts		
style B	32, 64	
style C	64, 96	32
Board thickness	1,42 to 1,78 mm	
Polarization	achieved by asymmetrical housing	
Insertion force and withdrawal force	see Table 1	
Retention force per contact, measured with mechanical gauge according to IEC 130-14	≥ 0,15 N	
Mechanical endurance	400 insertions, according to IEC 512-5, test 9a 500 insertions, according to VG 95324	
Connector body material	glass-fibre-filled thermoplastic	
	according to IEC 130-14/DIN 41612	according to VG 95324
Contacts of male part		
material	brass	brass
finish of contact surfaces	≥ 1,3 μm gold plate on ≥ 2 μm nickel plate	≥ 2,5 μm gold plate on ≥ 2 μm nickel plate
type of termination	● 90° angled dip-solder pin ● straight dip-solder pin ● solder tag ● 90° angled pin for wire wrapping	● 90° angled dip-solder pin
finish of termination	gold flash on 1 μm nickel plate	gold flash on 1 μm nickel plate
Contacts of female part		
material	phosphor bronze	phosphor bronze
finish of contact surfaces	≥ 1,3 μm gold plate on ≥ 2 μm nickel plate	≥ 3 μm gold plate on ≥ 2 μm nickel plate
type of termination	● pin for wire wrapping ● straight dip-solder pin ● solder tag ● 90° angled dip-solder pin	● pin for wire wrapping
finish of termination	gold flash on 2 μm nickel plate	gold flash on 2 μm nickel plate
Wire diameter	AWG30 to AWG26 (φ 0,25 to φ 0,40 mm)	
Mass	see Table 1	

	according to IEC 130-14/DIN 41612	according to VG 95324
Solderability	according to IEC 68, test T, 235 °C, 2 s	according to VG 95210, part 23, 230 °C, 5 s
Resistance to soldering heat	according to IEC 68, test T, 260 °C, 10 s	according to DIN 40046, part 18, 350 °C, 3,5 s
Shock		according to VG 95210, part 28, half sine pulse, 50 g, 11 ms, 3 directions, 10 shocks per direction
Vibration	according to IEC 68, test Fc, 10 to 500 Hz, 0,35 mm (p-p) or 5 g, 3 directions, 2 h per direction	according to VG 95210, part 19, 10 to 2000 Hz, 1,52 mm (p-p) or 20 g, 3 directions, 4 h per direction
Acceleration		according to VG 95210, part 27, 100g, 6 directions, 5 min per direction

Table 1

number of contacts	insertion force and withdrawal force N	approx. mass (g)	
		male part	female part
32	≤ 30	9,5	12
64	≤ 60	12	14,5
96	≤ 90	14,5	17,5

ENVIRONMENTAL DATA

Climatic category (IEC 68)	55/125/56	
Ambient temperature range	-55 to +125 °C	
Storage temperature range	-55 to +125 °C	
	according to IEC 130-14/DIN 41612	according to VG 95324
Damp heat, steady state	according to IEC 68, test Ca, 56 days, 40 °C, R.H. 90 to 95%	according to VG 95210, part 4, 56 days, 40 °C, R.H. 90 to 95%
Dry heat	according to IEC 68, test Ba, 2h, 125 °C	according to VG 95324, 16h, 125 °C
Salt mist		according to VG 95210, part 2, 5%, 48h
Low air pressure	according to IEC 68, test M, 5 min, 25 °C, 300 mbar	according to VG 95210, part 6, 5 min, 25 °C, 8 mm Hg
Industrial atmosphere	under consideration	according to VG 95319, part 2; after 250 opera- tions: SO ₂ , 1%, 24h, followed by H ₂ S, 1%, 24h
Flammability	according to UL94, category V1	according to VG 95210, part 12; time of flame application: 15 ± 1 s, burning time max. 10 s

DIMENSIONAL DATA

Dimensions in mm

Two-part connector, style B (2-row housing)

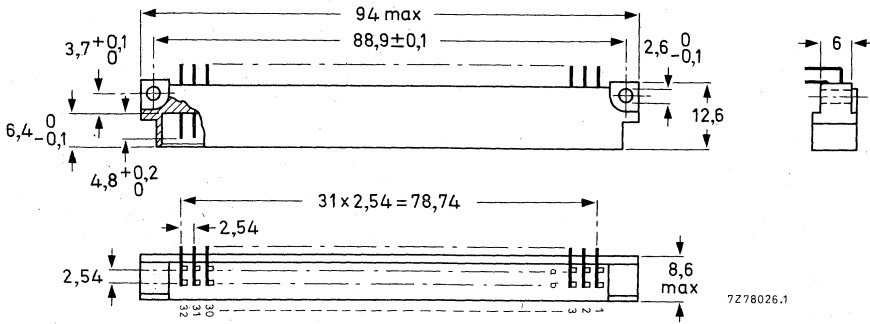

Fig. 2 Male part with 90° angled dip-solder pins.

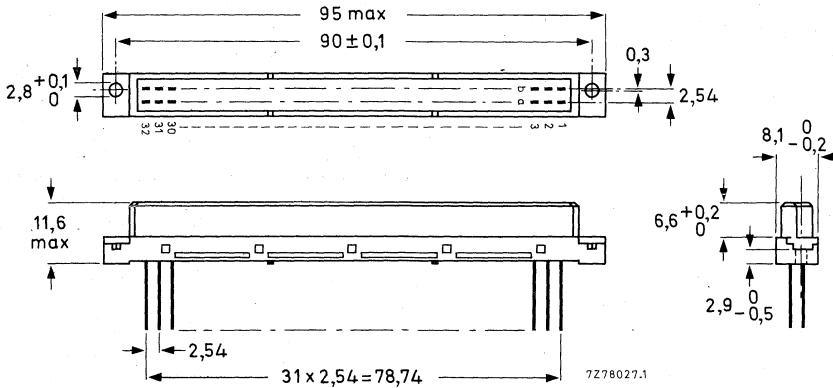

Fig. 3 Female part with pins for wire wrapping.

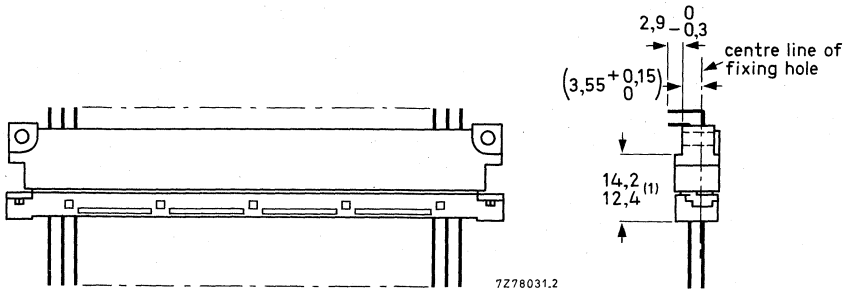

Fig. 4 Combination of connector parts shown in Figs 2 and 3.

(1) Reliable contact range.

Male parts

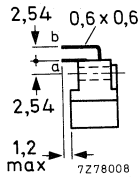

Fig. 5 90° angled dip-solder pins.

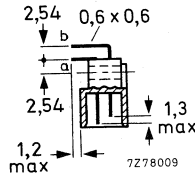

Fig. 6 90° angled dip-solder pins, with protruding earth contacts.

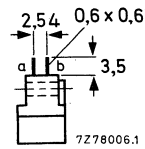

Fig. 7 Straight dip-solder pins.

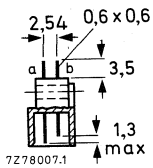

Fig. 8 Straight dip-solder pins, with protruding earth contacts.

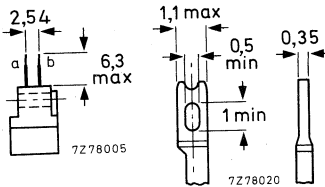

Fig. 9 Solder tags.

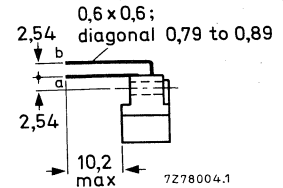

Fig. 10 90° angled pins for wire wrapping.

Female parts

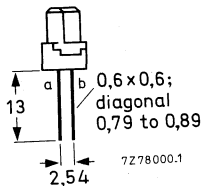

Fig. 11 Pins for wire wrapping.

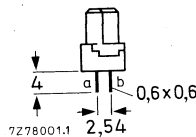

Fig. 12 Straight dip-solder pins.

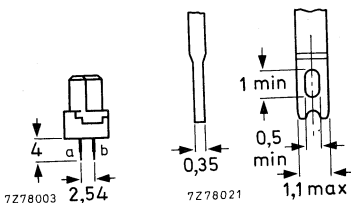

Fig. 13 Solder tags.

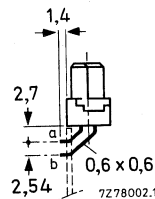

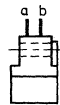

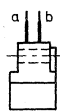
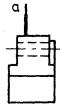
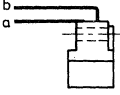
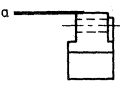



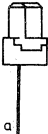

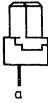

Fig. 14 90° angled dip-solder pins.

Table 2a Catalogue numbers for ordering male parts, style B

terminations	contacts		catalogue number of male part		
	positions occupied	number	according to IEC 130-14/ DIN 41612	without certificate	with certificate
	a1, a2, a3 to a32; b1, b2, b3 to b32	64	2422 025 89285 2422 025 89366 *	2422 025 89335	2422 025 89385
	a1, a2, a3 to a32	32	2422 025 89292 2422 025 89367 *	2422 025 89336	
	a1, a2, a3 to a32; b1, b2, b3 to b32	64	2422 025 89368 2422 025 89369 *		
	a1, a2, a3 to a32	32	2422 025 89404 2422 025 89371 *		
	a1, a2, a3 to a32; b1, b2, b3 to b32	64	2422 025 89372		
	a1, a2, a3 to a32	32	2422 025 89373		
	a1, a2, a3 to a32; b1, b2, b3 to b32	64	2422 025 89314		
	a1, a2, a3 to a32	32	2422 025 89315		

* With protruding earth contacts a1 and a32.

Table 2b Catalogue numbers for ordering female parts, style B

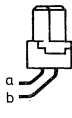
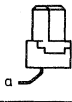
terminations	contacts		catalogue number of female part		
	positions occupied	number	according to IEC 130-14/ DIN 41612	according to VG 95324	
				without certificate	with certificate
	a1, a2, a3 to a32; b1, b2, b3 to b32	64	2422 025 89286	2422 025 89341	2422 025 89387
	a1, a2, a3 to a32	32	2422 025 89293	2422 025 89342	
	a1, a2, a3 to a32; b1, b2, b3 to b32	64	2422 025 89297	2422 025 89352	
	a1, a2, a3 to a32	32	2422 025 89302	2422 025 89353	
	a1, a2, a3 to a32; b1, b2, b3 to b32	64	2422 025 89329	2422 025 89346	
	a1, a2, a3 to a32	32	2422 025 89331	2422 025 89347	
	a1, a2, a3 to a32; b1, b2, b3 to b32	64	2422 025 89378		
	a1, a2, a3 to a32	32	2422 025 89377		

Two-part connector style C (3-row housing)

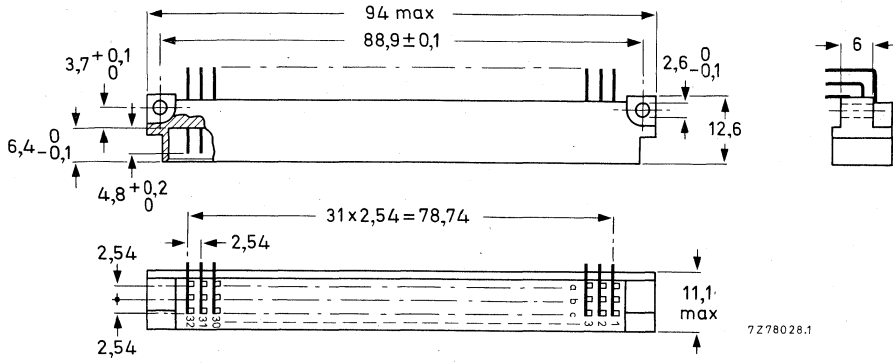

Fig. 15 Male part with 90° angled dip-solder pins.

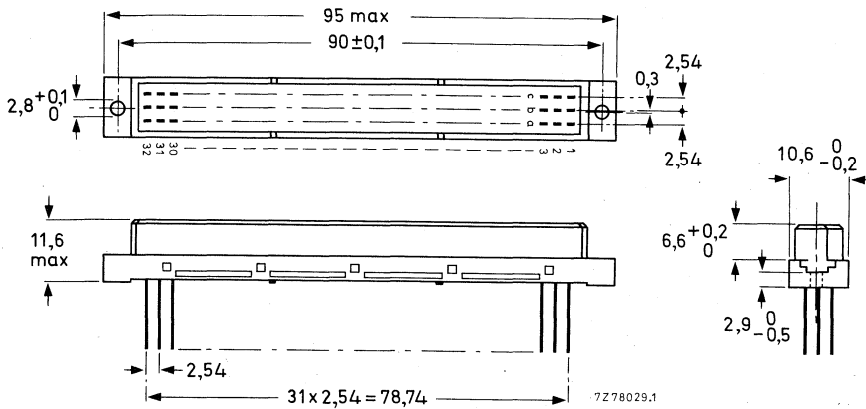

Fig. 16 Female part with pins for wire wrapping.

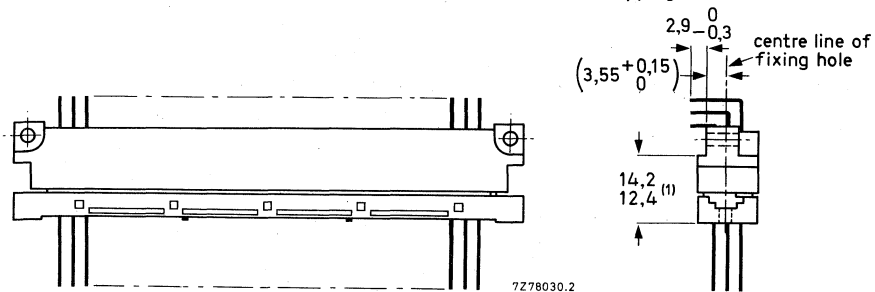

Fig. 17 Combination of connector parts shown in Figs 15 and 16.

(1) Reliable contact range.

Male parts

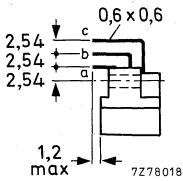

Fig. 18 90° angled dip-solder pins.

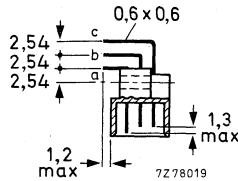

Fig. 19 90° angled dip-solder pins with protruding earth contacts.

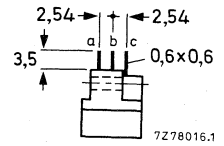

Fig. 20 Straight dip-solder pins.

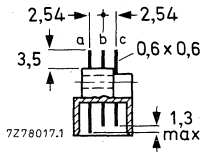

Fig. 21 Straight dip-solder pins, with protruding earth contacts.

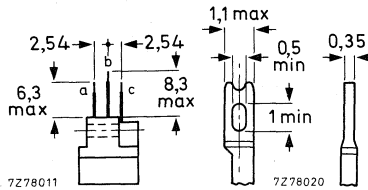

Fig. 22 Solder tags.

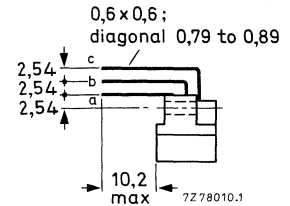

Fig. 23 90° angled pins for wire wrapping.

Female parts

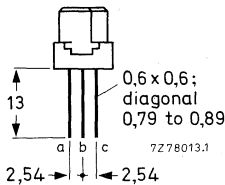

Fig. 24 Pins for wire wrapping.

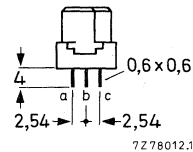

Fig. 25 Straight dip-solder pins.

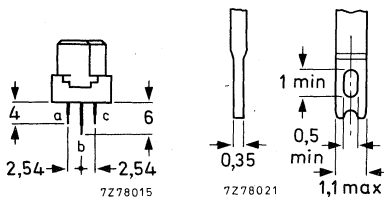

Fig. 26 Solder tags.

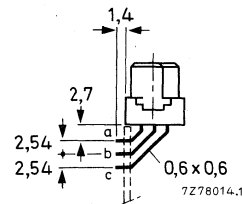

Fig. 27 90° angled dip-solder pins.

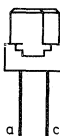

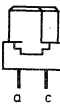

Table 3a Catalogue numbers for ordering male parts, style C

terminations	contacts		catalogue number of male part		
	positions occupied	number	according to IEC 130-14/ DIN 41612	according to VG 95324	
				without certificate	with certificate
	a1, a2, a3 to a32 b1, b2, b3 to b32; c1, c2, c3 to c32	96	2422 025 89283 2422 025 89354 *	2422 025 89332	2422 025 89386
	a1, a2, a3 to a32; c1, c2, c3 to c32;	64	2422 025 89287 2422 025 89355 *	2422 025 89333	
	a2, a4, a6 to a32; c2, c4, c6 to c32	32	2422 025 89289 2422 025 89356 **	2422 025 89334	
	a1, a2, a3 to a32 b1, b2, b3 to b32; c1, c2, c3 to c32	96	2422 025 89357 2422 025 89358 *		
	a1, a2, a3 to a32; c1, c2, c3 to c32	64	2422 025 89359 2422 025 89403 *		
	a2, a4, a6 to a32; c2, c4, c6 to c32	32	2422 025 89361 2422 025 89362 **		
	a1, a2, a3 to a32 b1, b2, b3 to b32; c1, c2, c3 to c32	96	2422 025 89363		
	a1, a2, a3 to a32; c1, c2, c3 to c32	64	2422 025 89364		
	a2, a4, a6 to a32; c2, c4, c6 to c32	32	2422 025 89365		
	a1, a2, a3 to a32; b1, b2, b3 to b32; c1, c2, c3 to c32	96	2422 025 89313		
	a1, a2, a3 to a32, c1, c2, c3 to c32	64	2422 025 89324		
	a2, a4, a6 to a32; c2, c4, c6 to c32	32	2422 025 89319		

* With protruding earth contacts a1 and a32.

** With protruding earth contacts a2 and a32.

Table 3b Catalogue numbers for ordering female parts, style C

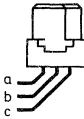
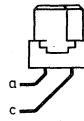
terminations	contacts		catalogue number of female part		
	positions occupied	number	according to IEC 130-14/ DIN 41612	according to VG 95324	
				without certificate	with certificate
	a1, a2, a3 to a32; b1, b2, b3 to b32; c1, c2, c3 to c32	96	2422 025 89284	2422 025 89337	2422 025 89388
	a1, a2, a3 to a32; c1, c2, c3 to c32	64	2422 025 89288	2422 025 89338	
	a2, a4, a6 to a32; c2, c4, c6 to c32	32	2422 025 89291	2422 025 89339	
	a1, a2, a3 to a32; b1, b2, b3 to b32; c1, c2, c3 to c32	96	2422 025 89296	2422 025 89348	
	a1, a2, a3 to a32; c1, c2, c3 to c32	64	2422 025 89298	2422 025 89349	
	a2, a4, a6 to a32; c2, c4, c6 to c32	32	2422 025 89299	2422 025 89351	
	a1, a2, a3 to a32; b1, b2, b3 to b32; c1, c2, c3 to c32	96	2422 025 89325	2422 025 89343	
	a1, a2, a3 to a32; c1, c2, c3 to c32	64	2422 025 89326	2422 025 89344	
	a2, a4, a6 to a32; c2, c4, c6 to c32	32	2422 025 89327	2422 025 89345	
	a1, a2, a3 to a32; b1, b2, b3 to b32; c1, c2, c3 to c32	96	2422 025 89382		
	a1, a2, a3 to a32; c1, c2, c3 to c32	64	2422 025 89405		
	a2, a4, a6 to a32; c2, c4, c6 to c32	32	2422 025 89379		

MOUNTING

Dimensions in mm

Panel cut-out for female parts

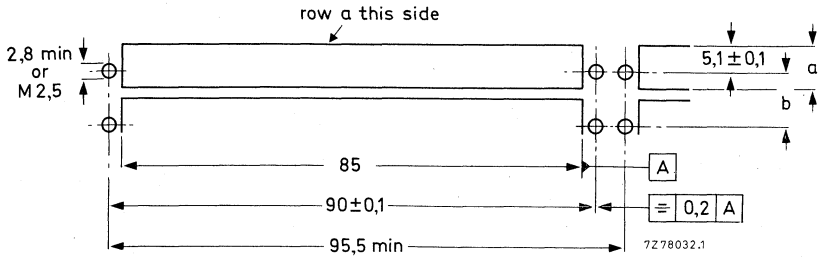

Fig. 28 Panel cut-out; see Table 4 for dimensions a and b.

Table 4

connector style	a _{min}	b _{min}
B	8,3	10,16
C	10,8	12,7

Hole pattern on printed boards for female parts

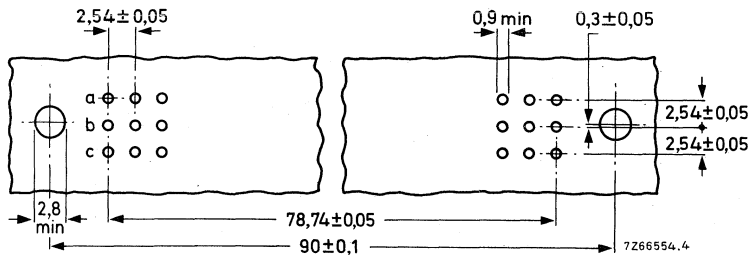

Fig. 29 For 3 x 32 contacts (style C).

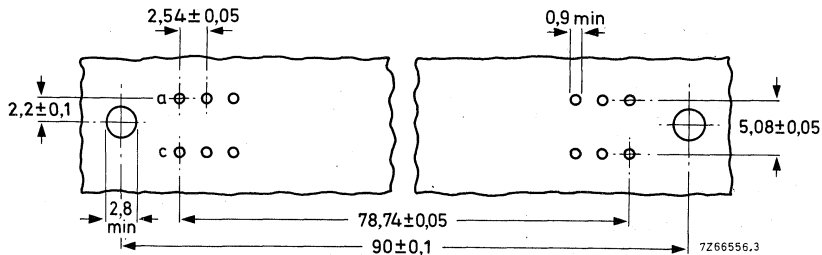

Fig. 30 For 2 x 32 contacts (style C).

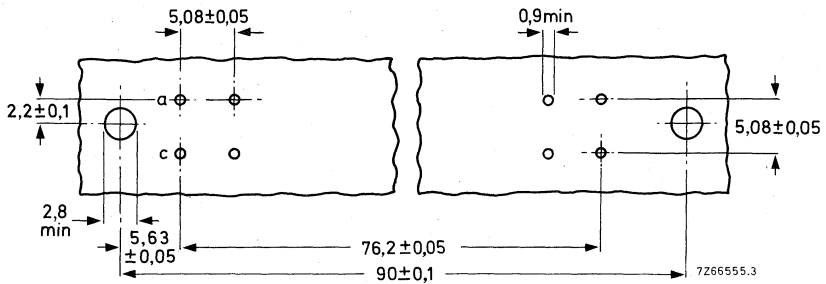

Fig. 31 For 2 x 16 contacts (style C).

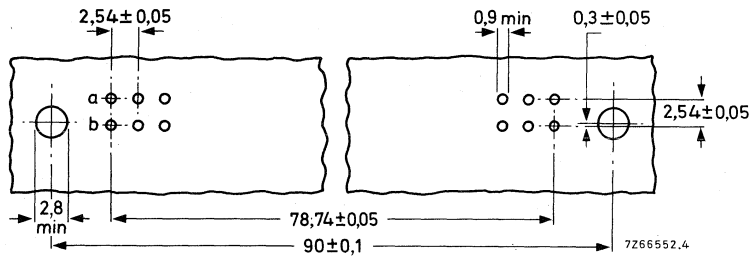

Fig. 32 For 2 x 32 contacts (style B).

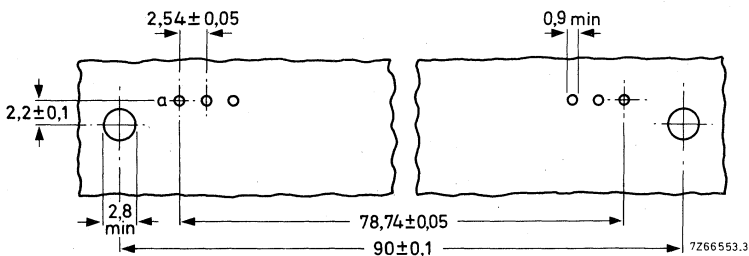

Fig. 33 Fig. 1 x 32 contacts (style B).

Note: For mounting of female parts with 90° angled dip-solder pins, see page 29.

Hole pattern on printed boards for male parts

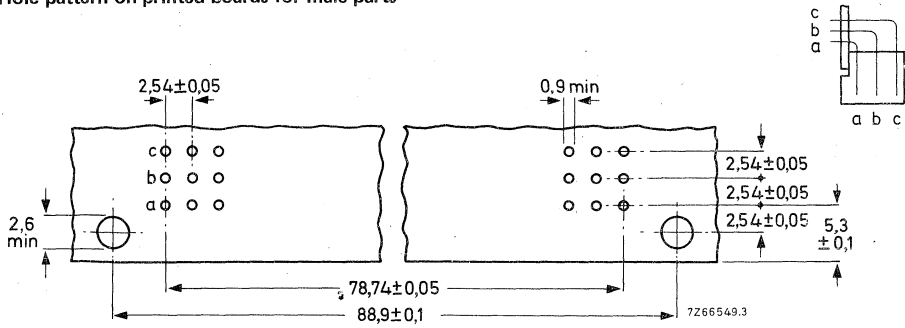

Fig. 34 For 3 x 32 contacts (style C).

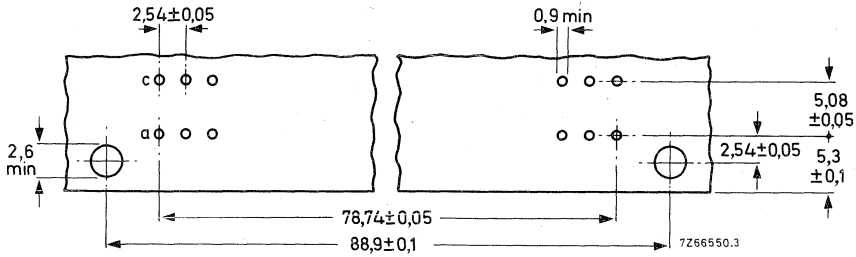

Fig. 35 For 2 x 32 contacts (style C).

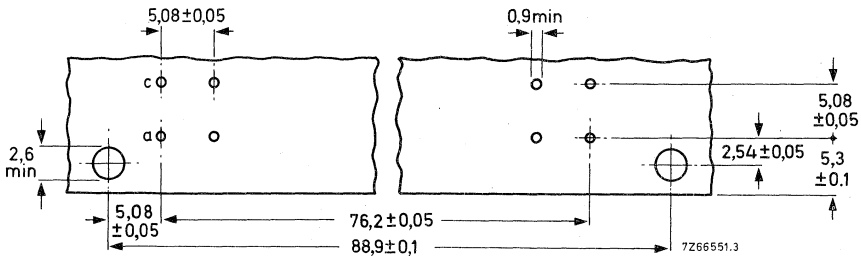

Fig. 36 For 2 x 16 contacts (style C).

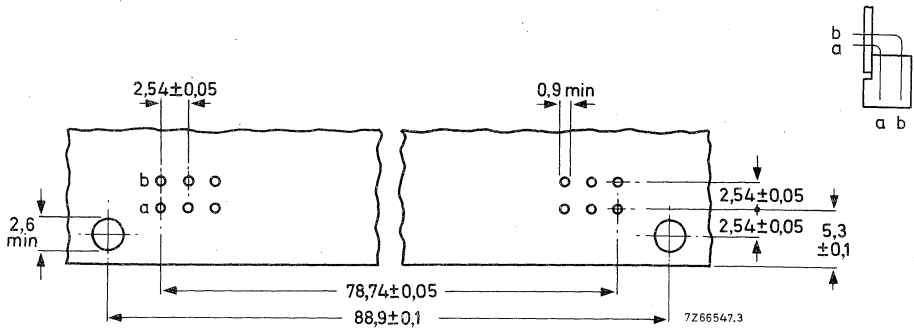

Fig. 37 For 2 x 32 contacts (style B).

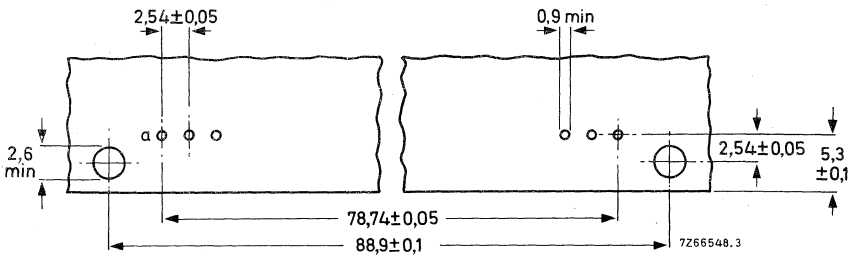

Fig. 38 For 1 x 32 contacts (style B).

MARKING

Package

The package is marked with:
 12-digit catalogue number;
 reference number of manufacturer;
 number of pieces.

Connector

The bodies of the male and female parts are marked with:
 12-digit catalogue number;
 type number;
 reference number of manufacturer;
 name of manufacturer.

The terminations are marked as shown in the table below.

Table 5

style	male part	female part
B		
C		

ACCESSORIES

Dimensions in mm

Cable hood

A hood of grey thermoplastic material for cable mounting can be supplied. The hood consists of two identical parts; it is suitable for use with both male and female parts. It is provided with three cable inlets, covered with snap-in plugs. The component parts of the hood are supplied unassembled in a plastic bag. A cable clamp with two screws is supplied with each hood. Separate cable clamps can be supplied under catalogue number 4332 026 30280; please order in multiples of 5. Use of the cable hood with a connector of style B requires the use of a packing piece. Locking clips and brackets are available for different applications (see Figs 41, 42 and 43).

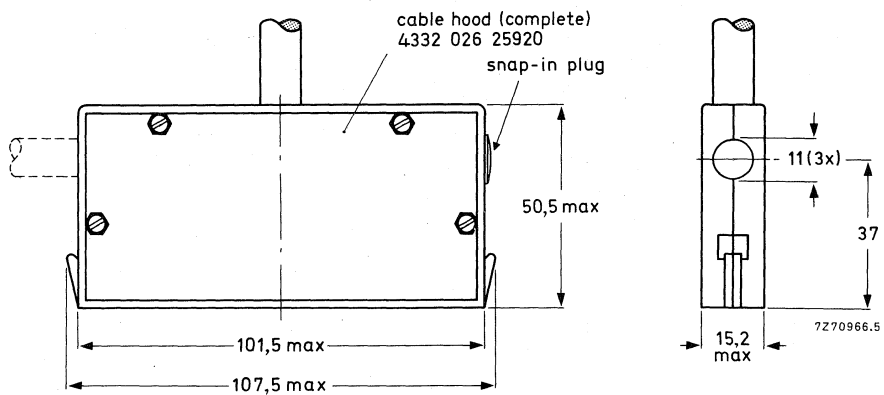

Fig. 39 Assembled cable hood.

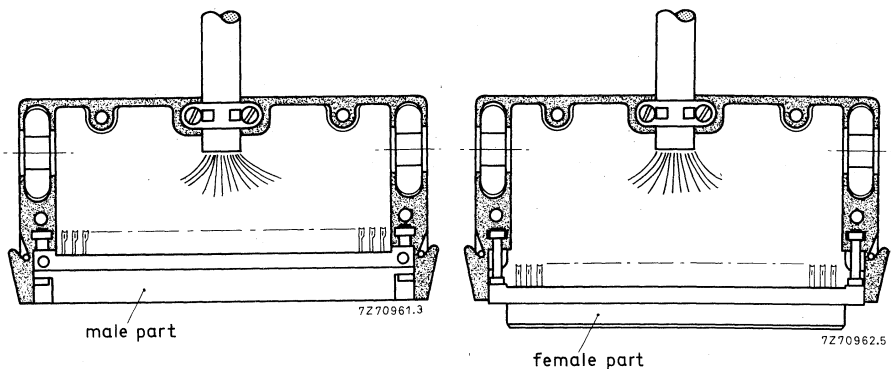

Fig. 40 Fixing of cable to the hood and mounting of the hood to the connector part. Maximum permissible cable diameter is 11 mm (e.g. 96 insulated wires AWG30).

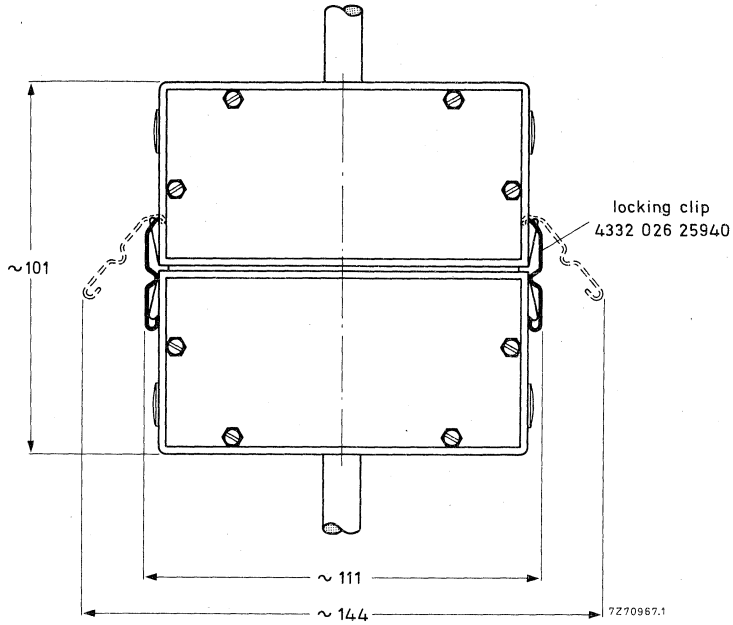

Fig. 41 Cable to cable application.

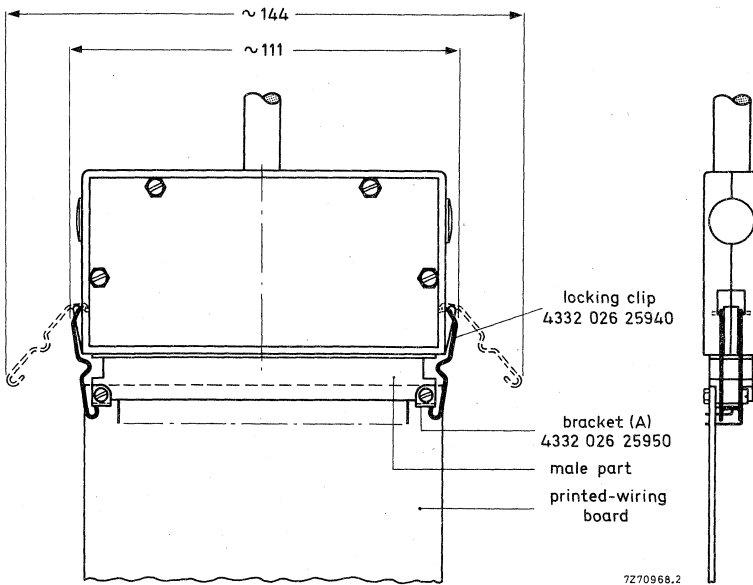

Fig. 42 Cable to printed-wiring board application.

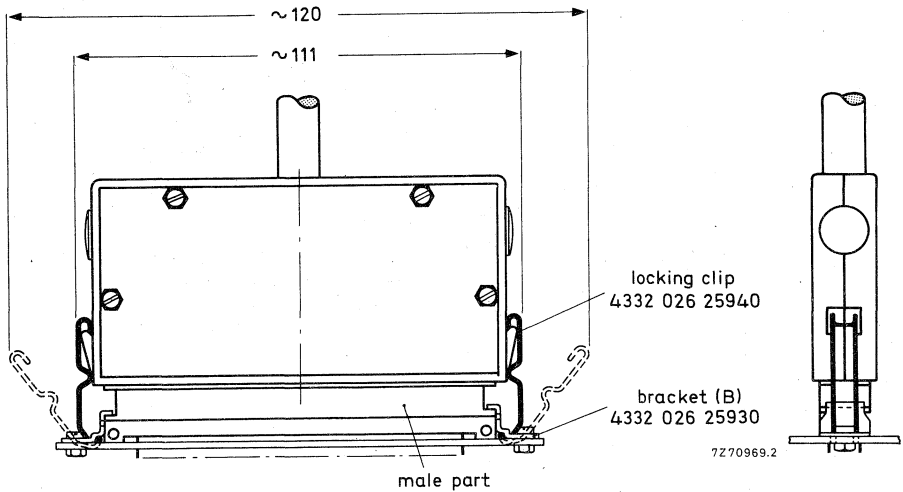

Fig. 43 Cable to panel application.

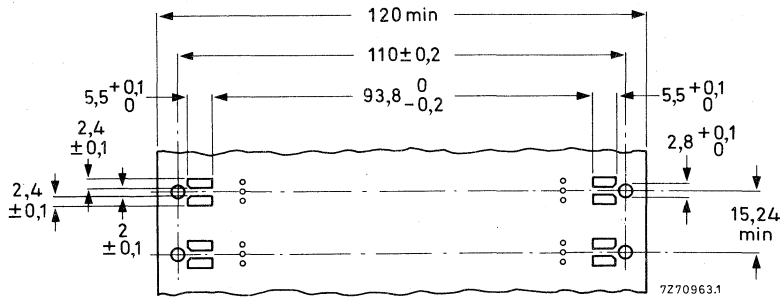

Fig. 44 Hole pattern on printed board for cable to panel application.

Table 6 Catalogue numbers for ordering accessories

accessory	catalogue number
cable hood (complete)	4332 026 25920
locking clip	25940
bracket (B), see Fig. 43	25930
bracket (A), see Fig. 42	25950
packing piece, for use with connector style B	26070

For packing of these accessories see page 30.

Coding parts

A set of coding parts can be supplied. They prevent insertion of the male part into the wrong female part. The set consists of an aluminium key strip for the male part; an aluminium keyway strip for the female part, and two polycarbonate keys. The strips are fixed to their relevant connector part by means of the connector mounting screws.

The key is pushed over the selected position of the key strip and the corresponding tooth of the keyway strip (Fig. 45a) broken off by means of a pair of pliers. Both strips are marked 1 to 16 inclusive, to facilitate location of the key. Maximum number of key locations with one key is 16; with two keys 120.

For use with male parts with 90° angled pins, the coding parts can be applied in two ways, as shown in Figs 45a and 45b; mounting according to Fig. 45b requires the use of the spacer.

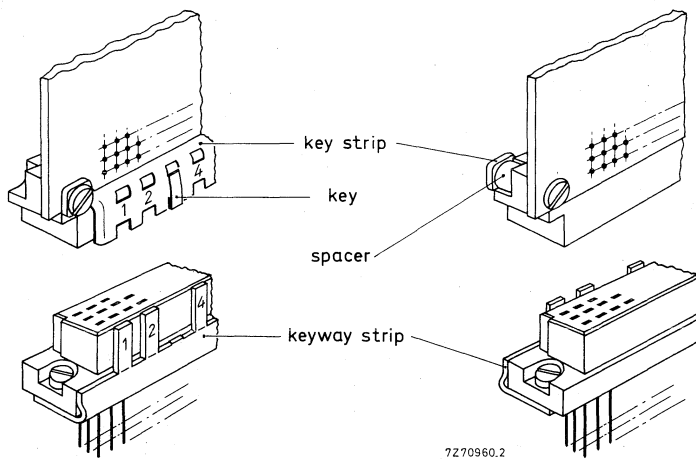

Fig. 45a Coding parts; key strip mounted to solder side of printed board.

Fig. 45b Coding parts; key strip mounted to male part on component side of printed board.

The set of coding parts is supplied in a plastic bag (5 sets per bag). For mounting according to Fig. 45b, the same set with spacers for style B and style C connectors is supplied in the same way, see also Table 7.

Mass of key strip:	2,0 g
of keyway strip:	2,8 g
of key:	0,06 g

Notes

Minimum centre-to-centre distance between two adjacent connectors of style B is 12,7 mm and of style C, 15,24 mm.

The female part is raised 1 mm above the panel (thickness of the keyway strip).

The coding system cannot be applied to a connector with cable hood.

The use of coding parts with male parts with straight dip-solder pins is shown in Figs 46a and 46b.

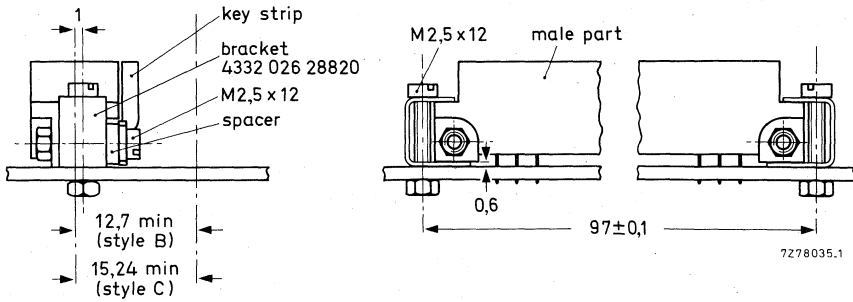

Fig. 46a Key strip mounted to a male part with straight dip-solder pins.

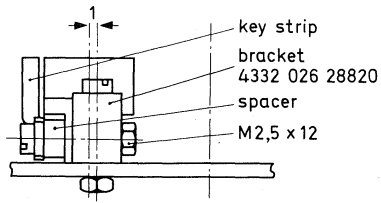

Fig. 46b Key strip mounted to a male part with straight dip-solder pins.

Coding parts with the required spacers for mounting according to Figs 46a and 46b are supplied in plastic bags of 5 sets; see also Table 7.

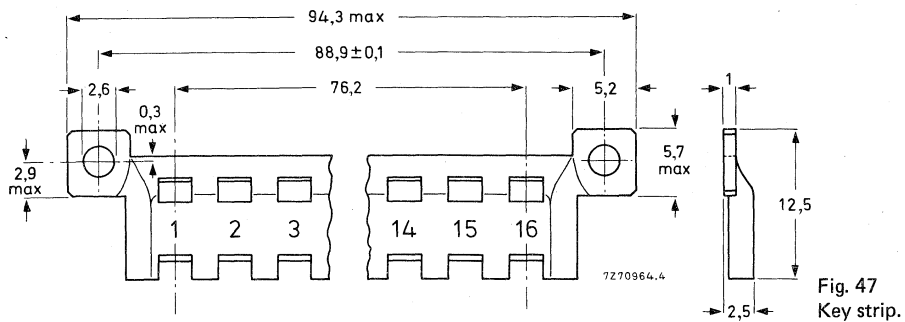

Fig. 47
Key strip.

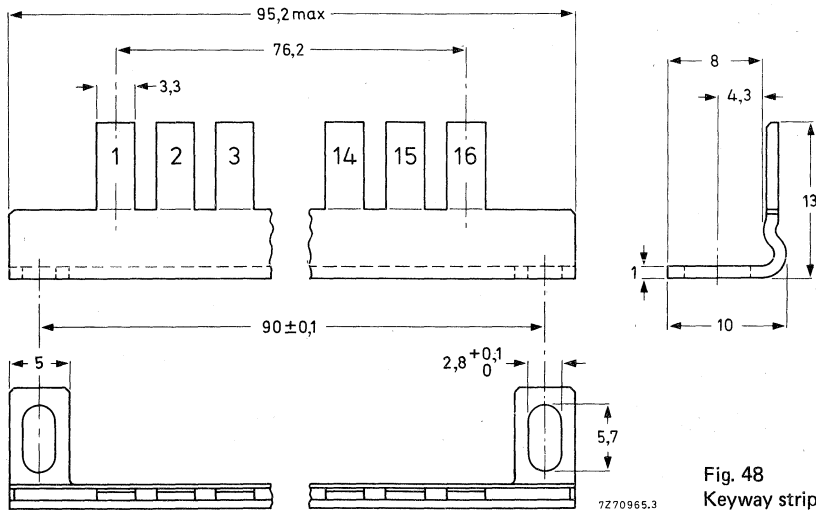

Fig. 48
Keyway strip.

Table 7 Catalogue numbers for ordering accessories

accessory	catalogue number
set of coding parts for mounting according to Fig. 45a (note 1)	4332 026 30250
set of coding parts for mounting according to Figs 45b, 46b (note 2)	30260
set of coding parts for mounting according to Fig. 46a (note 3)	30270
bracket for mounting of male part (Figs 46a, 46b)	28820

For packing of these accessories see page 30.

Notes

1. 1 key strip, 1 keyway strip, 2 keys.
2. 1 key strip, 1 keyway strip, 2 keys, 2 spacers for style B, 2 spacers per style C.
3. 1 key strip, 1 keyway strip, 2 keys, 2 spacers.

Accessories for female parts with pins for wire wrapping

For connection of a cable to the wire wrapping pins of a female part, e.g. at the rear of a back panel, a set of accessories is available: receptacle, distance pieces, locking clips and screws M2,5 x 5 (Fig. 49). The receptacle permits the wrapping of one wrap per pin up to AWG30. Use of female parts of style B requires the use of a packing piece in the receptacle.

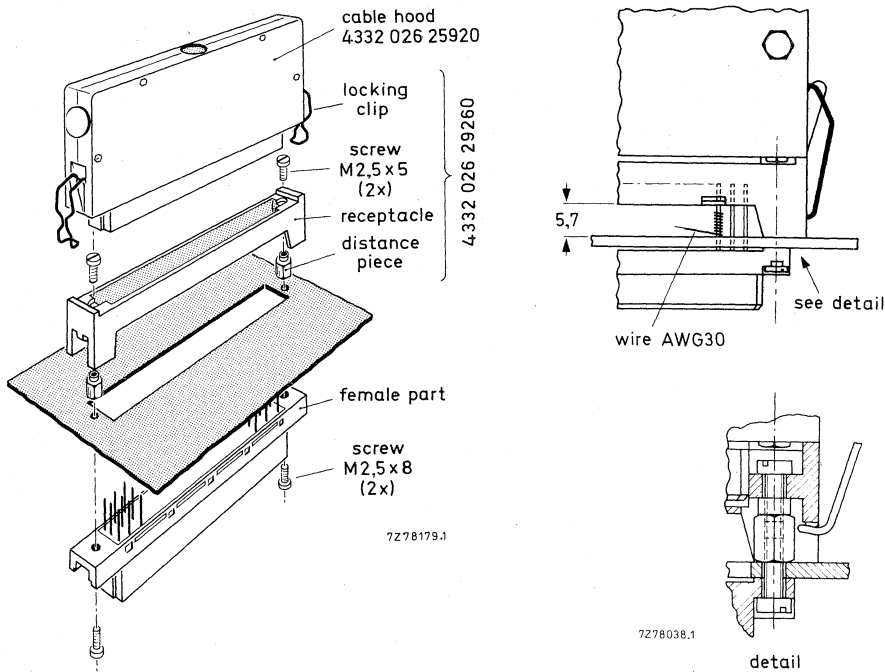

Fig. 49 Accessories for female parts with pins for wire wrapping.

Table 8 Catalogue numbers for ordering accessories

accessory	catalogue number
set of accessories, consisting of 1 receptacle, 2 distance pieces, 2 locking clips, 2 screws M2,5 x 5	4332 026 29260
packing piece	29090

For packing of these accessories see page 30.

Mounting brackets for female parts with 90° angled dip-solder pins

A mounting bracket with locking facility is available for fitting female parts with 90° angled pins to printed boards (Fig. 50) or to extension boards (Fig. 51). Two types of clips can be supplied for locking to the cable hood and to the male part respectively.

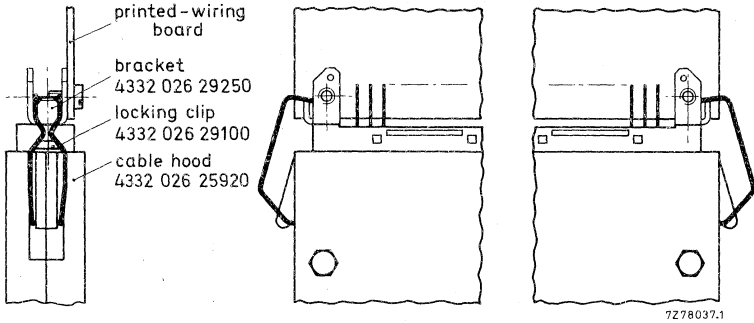

Fig. 50 Mounting of a female part to a board with bracket having locking facility.

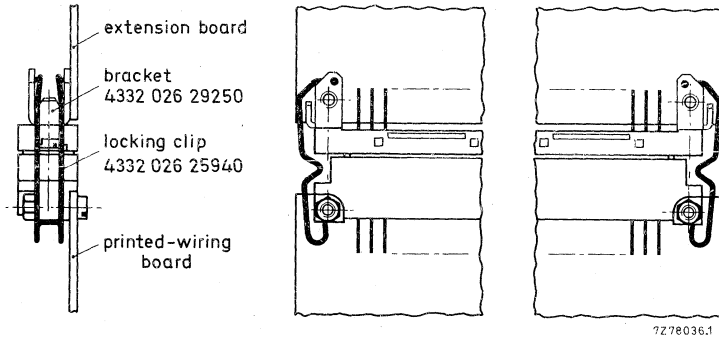

Fig. 51 Mounting of a female part to an extension board with bracket having locking facility.

Another mounting bracket for fitting female parts with 90° angled pins to printed boards is shown in Fig. 52. The bracket is provided with two M2,5 holes. The hole pattern of the board is shown in Fig. 52.

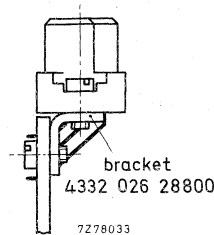

Fig. 52 Mounting of a female part to a board.

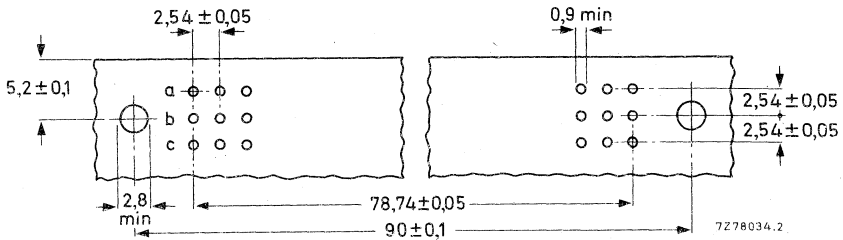

Fig. 53 Hole pattern of the board for a female part with 3 x 32 contacts (style C): for 2 x 32 contacts (style B) the holes of row c are omitted.

Table 9 Catalogue numbers for ordering accessories

accessory	catalogue number
mounting bracket (Fig. 52)	4332 026 28800
mounting bracket (Figs 50 and 51)	29250
clip for locking to a cable hood (Fig. 50)	29100
clip for locking to a male part (Fig. 51)	25940

For packing of these accessories see page 30.

PACKING**Connectors**

The connectors are packed in boxes: style B 25 per box, style C 20 per box. Please order in multiples of these quantities.

Accessories

The accessories are packed in plastic bags; the number of pieces or sets per bag is given in Table 10. Please order in multiples of the stated quantities.

Table 10

accessory	catalogue number	number of pieces per bag	number of sets per bag
cable hood (unassembled) with associated parts (Fig. 39)	4332 026 25920		1
packing piece for use with cable hood	26070	5	
locking clip (Figs 41, 42, 43, 51)	25940	10	
locking clip (Fig. 50)	29100	10	
set of coding parts (Fig. 45a)	30250		5 (note 1)
set of coding parts (Figs 45b, 46b)	30260		5 (note 2)
set of coding parts (Fig. 46a)	30270		5 (note 3)
mounting bracket for male part (Fig. 43)	25930	10	
mounting bracket for male part (Fig. 42)	25950	10	
mounting bracket for male part (Figs 46a, 46b)	28820	10	
mounting bracket for female part (Fig. 52)	28800	10	
mounting bracket for female part (Figs 50, 51)	29250	10	
accessory set for female part (Fig. 49)	29260		5 (note 4)
packing piece for use with receptacle	29090	5	

Notes

1. Each set consists of: 1 key strip, 1 keyway strip, 2 keys.
2. Each set consists of: 1 key strip, 1 keyway strip, 2 keys, 2 spacers for style B, 2 spacers for style C.
3. Each set consists of: 1 key strip, 1 keyway strip, 2 keys, 2 spacers.
4. Each set consists of: 1 receptacle, 2 distance pieces, 2 locking clips, 2 screws M2,5 x 5.

TWO-PART PRINTED-WIRING CONNECTORS

- For basic grid of 5,08 mm (0,2 in)

QUICK REFERENCE DATA

Contact pitch	5,08 mm (0,2 in)
Number of contacts	
style F	32, 48
style G	64
Board thickness	1,42 to 1,78 mm
Terminations	
male part	90° angled dip-solder pins
female part	straight dip-solder pins * pins for wire wrapping
Current at $T_{amb} = 20\text{ }^{\circ}\text{C}$	5,5 A
Mechanical endurance	400 insertions
Climatic category (IEC 68)	55/125/56
Detail specifications	IEC 130, DIN 41612 and VG 95324 **

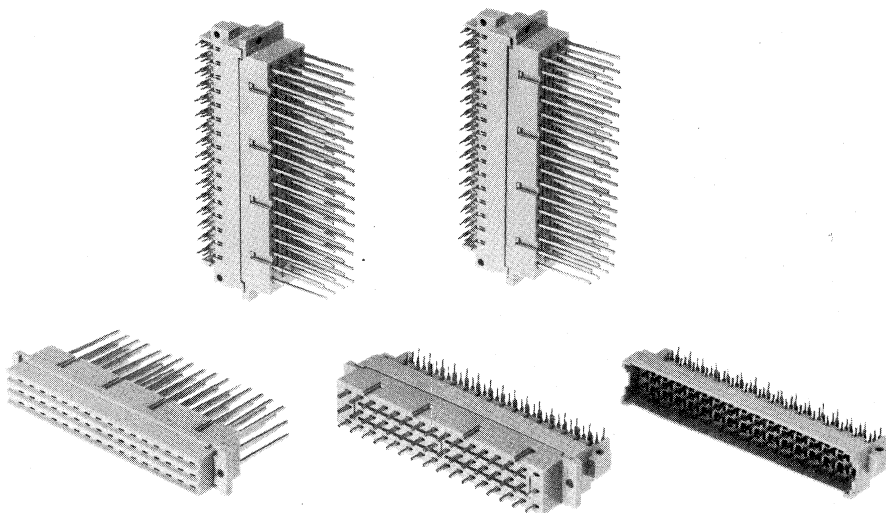

* Only 32 and 48 connections.

** German military standard.

APPLICATION

For use in applications where high current and/or high voltage operation is required. For signal connections the complementary F068-I series of connectors can be employed. The combination of F068-I and F068-II connectors is ideal for a wide range of professional applications, including those having severe industrial environments.

DESCRIPTION

The connectors consist of a male part to be fitted to a printed-wiring board and a female part to be mounted on a chassis or a back panel. Both parts have a grey body of glass-fibre-filled thermoplastic material.

The contact springs of the female part are of phosphor bronze, the contact pins of the male part are of brass; the contact surfaces are gold on nickel plating. The contact terminations of both parts are tinned. The contact springs of the female part are reinforced with a steel spring, which gives an extra guarantee for reliable functioning under severe conditions of continuous load, vibration, etc. Female parts with non-reinforced springs are also available. The male parts are supplied with protruding earth contacts, which are approx. 1,5 mm longer than the other contacts. Removal of contacts from the male part can be done by means of a tool, see Accessories. No special provisions are required for polarization.

ELECTRICAL DATA

Current at $T_{amb} = 20\text{ }^{\circ}\text{C}$	5,5 A
Derated current curve	according to IEC 512-3, test 5b, see Fig.1
Contact resistance (including material resistance) at 10 mA, max 20 mV(peak) open circuit voltage, 1 kHz	
initially	$\leq 15\text{ m}\Omega$
after mechanical endurance	$\leq 15\text{ m}\Omega$
after damp heat test (IEC 68, test Ca)	$\leq 15\text{ m}\Omega$
Insulation resistance	
initially	$> 10^6\text{ M}\Omega$
after damp heat test (IEC 68, test Ca)	$> 10^4\text{ M}\Omega$
Creepage distance	
between contacts	$\geq 3\text{ mm}$ (Notes 1 and 2)
between a contact and earth	$\geq 6\text{ mm}$ (Note 1)
Clearance	
between contacts	$\geq 1,6\text{ mm}$
between a contact and earth	$\geq 3,5\text{ mm}$ } Note 1
Proof voltage for 1 min, at $20\text{ }^{\circ}\text{C}$	
between contacts	1550 V(r.m.s.), 50 Hz
between a contact and earth	2500 V(r.m.s.), 50 Hz
Capacitance between contacts at 1 kHz	$\leq 2\text{ pF}$

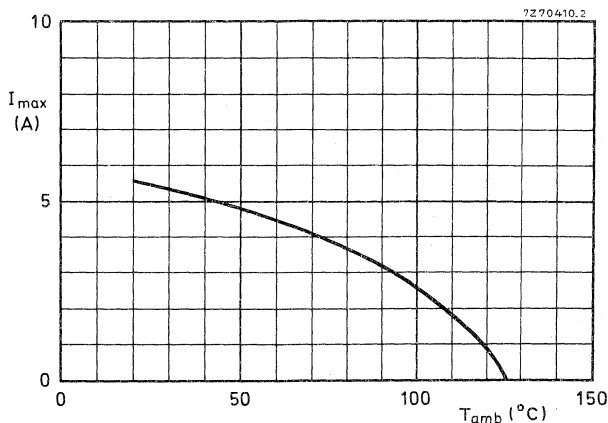

Fig.1 Maximum current per contact, equally on all contacts, as a function of ambient temperature (20% derated).

Notes

1. This value may be reduced by the wiring and/or the printed-wiring boards.
2. Between rows z and f (style G): $\geq 1,9\text{ mm}$.

MECHANICAL DATA

Contact pitch	5,08 mm(0,2 in)	
Number of contacts	32, 48	
style F	64	
style G		
Board thickness	1,42 to 1,78 mm	
Polarization	by means of asymmetrical position of the contacts	
Insertion force and withdrawal force	see Table 1	
Withdrawal force per contact, measured with mechanical gauge according to DIN 41612	≥ 0,2 N	
Mechanical endurance	400 insertions, according to IEC 512-5, test 9a	
Connector body material	glass-fibre-filled thermoplastic	
Contacts	male part	female part
material	brass	phosphor bronze
shape	rectangular pin	solid cantilever
finish of contact surfaces	≥ 1 μm gold plate on ≥ 3 μm nickel plate	≥ 2 μm rolled-on gold on ≥ 2 μm nickel plate
type of termination	90° angled dip-solder pin	dip-solder pin pin for wire wrapping
finish of termination	≥ 6 μm tinned	≥ 6 μm tinned
Wire diameter	AWG22 to AWG28 (φ0,64 to φ0,32 mm)	
Mass	see Table 1	
Solderability	235 °C, 2 s	} according to DIN 40046, test Ta, page 18
Resistance to soldering heat	260 °C, 10 s	
Vibration	according to DIN 40046, page 8, 10 to 500 Hz, 0,35 mm(p-p) or 5g, 3 directions, 2 h per direction	

Table 1

number of contacts	insertion force and withdrawal force N	approx. mass (g)	
		male part	female part
32	≤ 50	18	34
48	≤ 75	22	40
64	≤ 100	33	57

ENVIRONMENTAL DATA

Climatic category (IEC 68)

Ambient temperature range

Storage temperature range

Damp heat, steady state

Dry heat

Low air pressure

Flammability

55/125/56

-55 to +125 °C

-55 to +125 °C

according to DIN 40046, page 5,
56 days, 40 °C, R.H. 90 to 95%

according to DIN 40046, page 4,
16 h, 125 °C

according to DIN 40046, page 13,
2 min, 22 °C, 300 mbar

according to UL94, category V1

DIMENSIONAL DATA

Two-part connectors with 32 contacts (style F)

Dimensions in mm

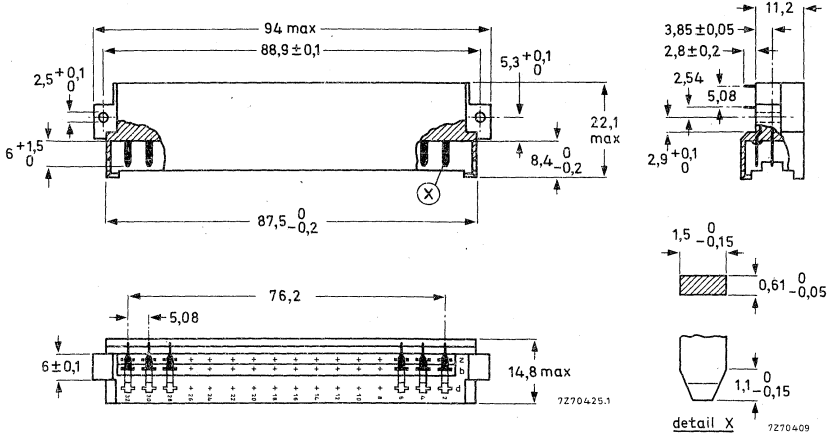

Fig. 2a Male part with 90° angled dip-solder pins.

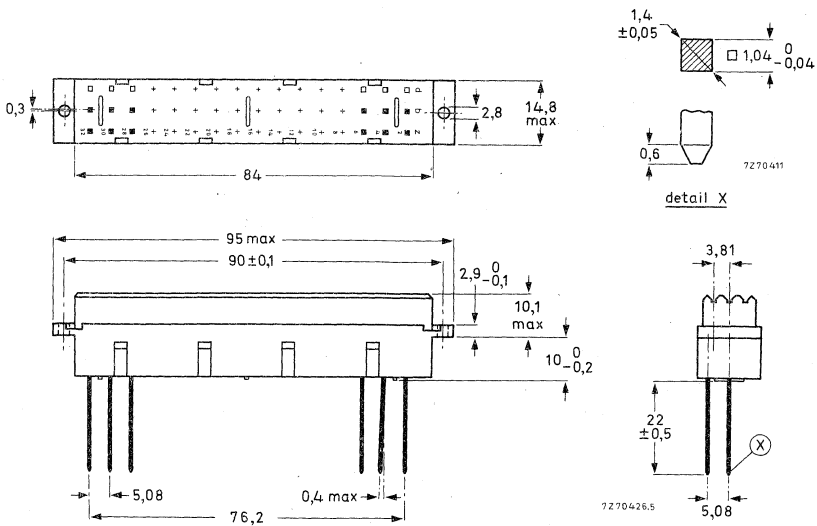

Fig.2b Female part with pins for wire wrapping.

Fig. 2c Female part with dip-solder pins.

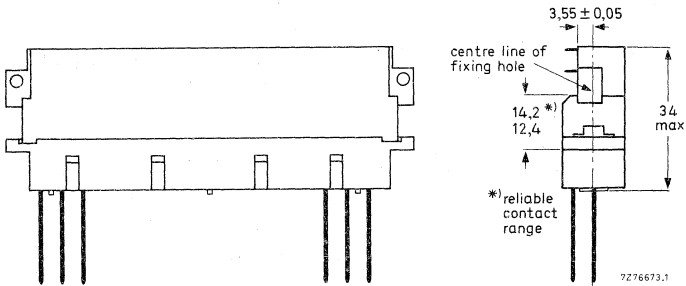
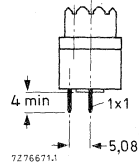

Fig. 2d Combination of connector parts shown in Figs 2a and 2b.

Table 2

connector part	terminations	protruding earth contacts	catalogue number
male	90° angled dip-solder pins	b2 and b32	2422 025 88032*
		z32	88035
		b2, b32 and z2	88038
female; with reinforced springs	pins for wire wrapping		88046*
	straight dip-solder pins		88049*
female; with non-reinforced springs	pins for wire wrapping		88061
	straight dip-solder pins		88064

* Preferred.

Two-part connectors with 48 contacts (style F)

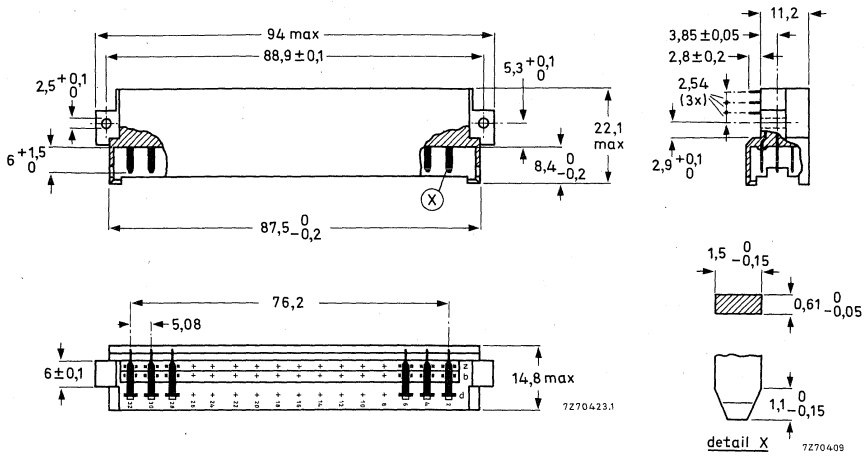

Fig. 3a Male part with 90° angled dip-solder pins.

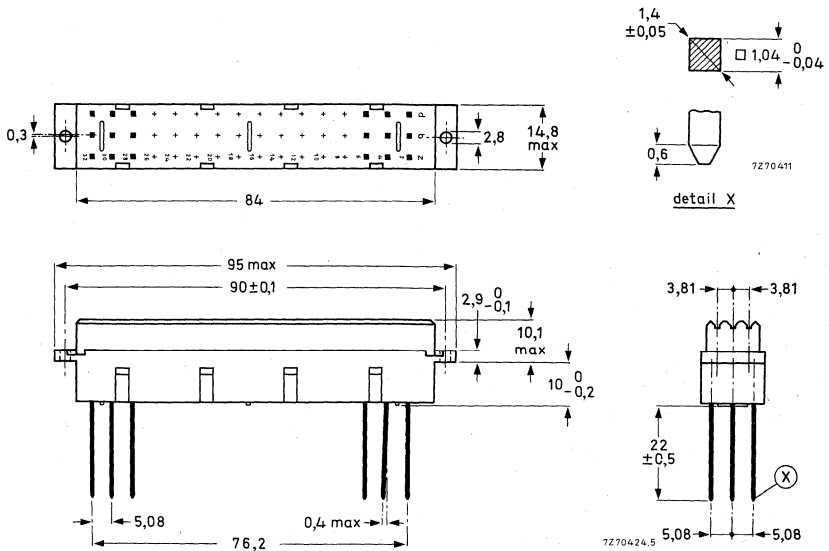

Fig. 3b Female part with pins for wire wrapping.

Fig. 3c Female part with dip-solder pins.

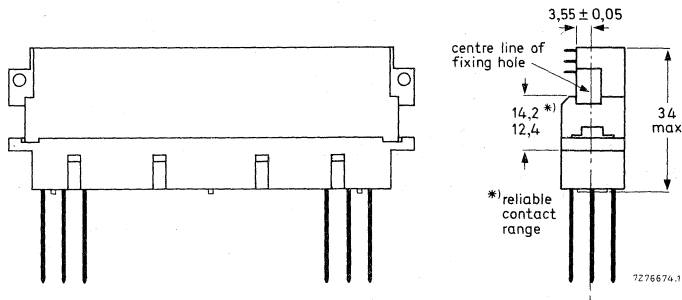
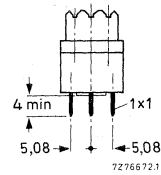

Fig. 3d Combination of connector parts shown in Figs 3a and 3b.

Table 3

connectors part	terminations	protruding earth contacts	catalogue number
male	90° angled dip-solder pins	b2 and b32	2422 025 88033*
		z32	88036
		b2, b32 and z2	88039
female; with reinforced springs	pins for wire wrapping		88047*
	straight dip-solder pins		88051*
female; with non-reinforced springs	pins for wire wrapping		88062
	straight dip-solder pins		88065

* Preferred.

Two-part connectors with 64 contacts (style G)

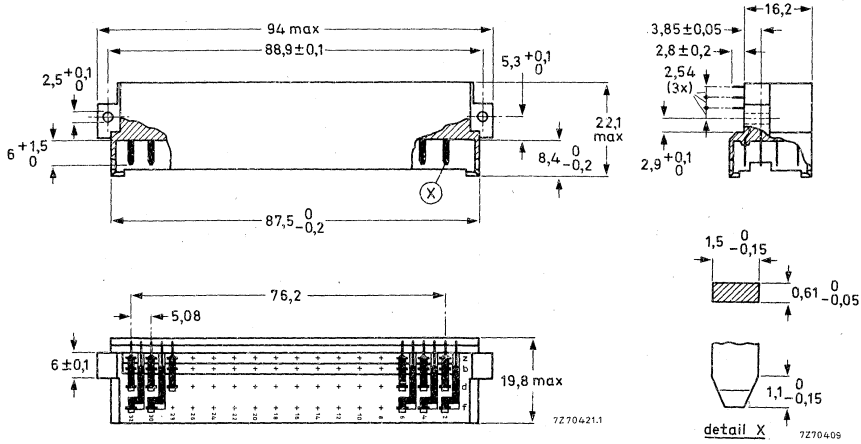

Fig. 4a Male part with 90° angled dip-solder pins. The pitch between the pins of rows z and f is 2,54 mm instead of 5,08 mm.

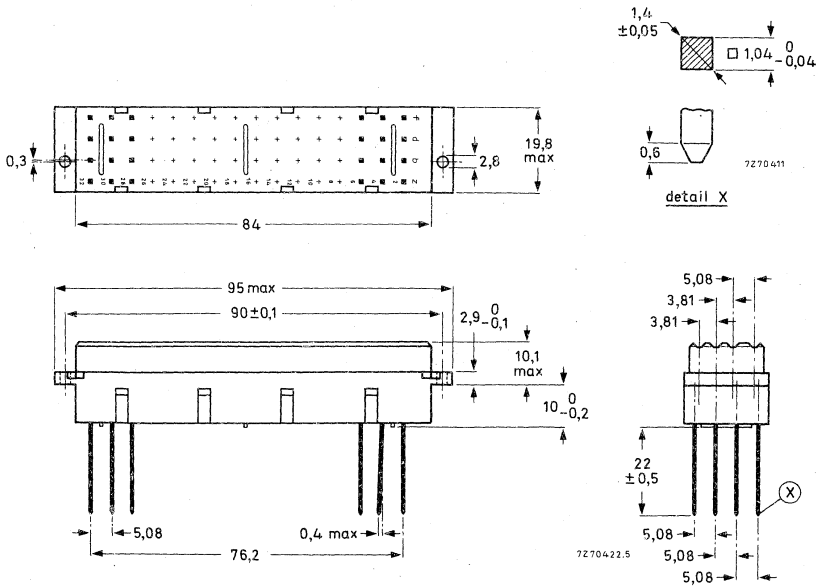

Fig. 4b Female part with pins for wire wrapping.

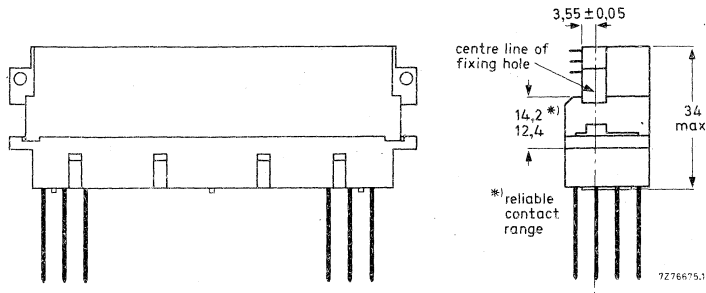

Fig. 4c Combination of connector parts shown in Figs 4a and 4b.

Table 4

connector part	terminations	protruding earth contacts	catalogue number
male	90° angled dip-solder pins	b2 and b32	2422 025 88034*
		z32	88037
		b2, b32 and z2	88041
female; with reinforced springs	pins for wire wrapping		88048*
female; with non-reinforced springs	pins for wire wrapping		88063

* Preferred.

MOUNTING

Dimensions in mm

Panel cut-out for female parts

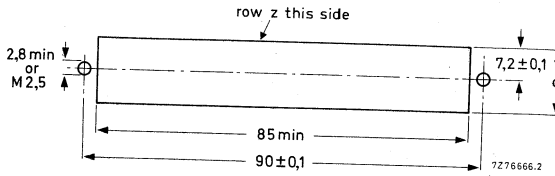

Fig. 5 Panel cut-out; see Table 5 for dimension a.

Table 5

number of contacts	a_{min}
32	15
48	15
64	20

Hole pattern on printed boards for female parts

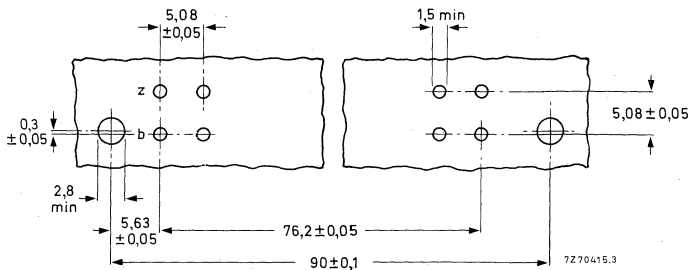

Fig. 6a For 32 contacts (style F).

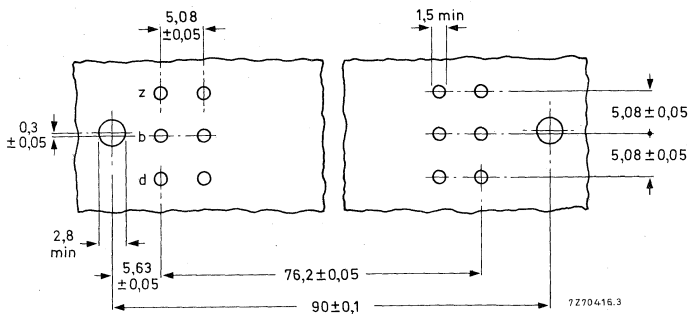

Fig. 6b For 48 contacts (style F).

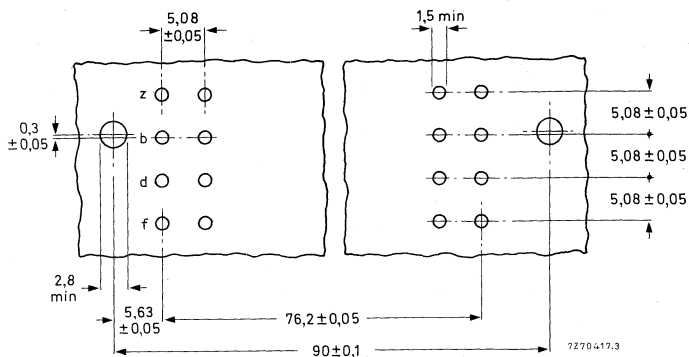

Fig. 6c For 64 contacts (style G).

Hole pattern on printed boards for male parts

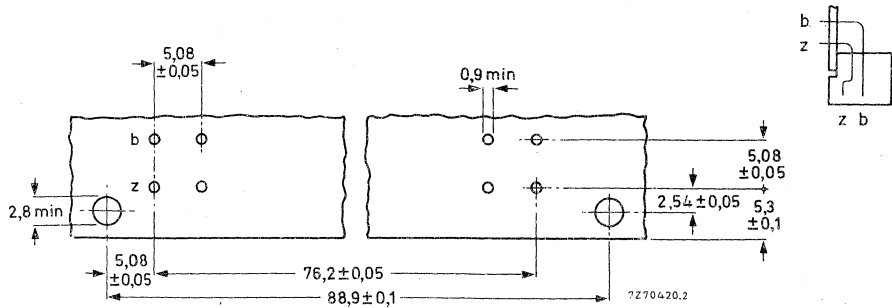

Fig. 7a For 32 contacts (style F).

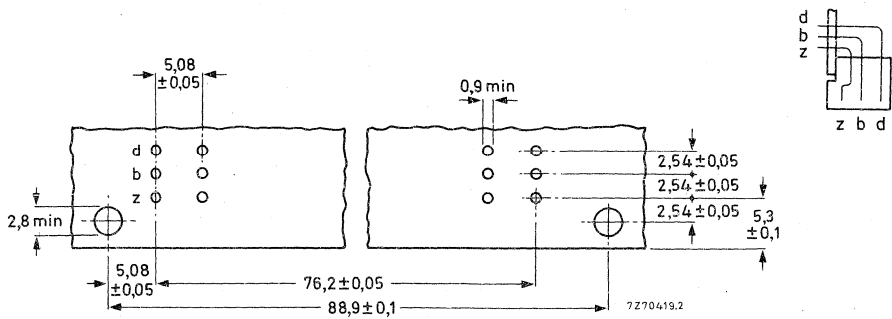

Fig. 7b For 48 contacts (style F).

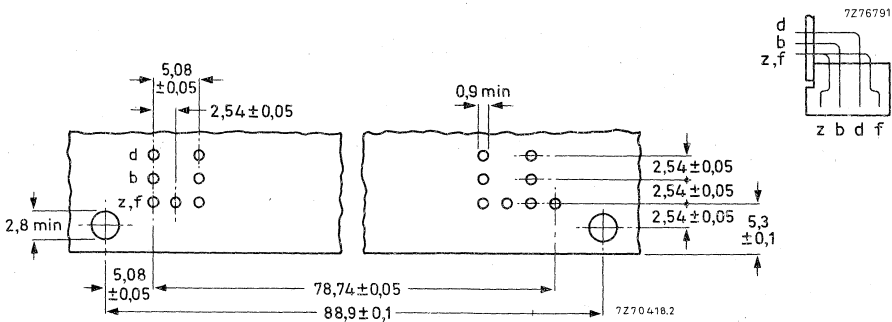

Fig. 7c For 64 contacts (style G).

MARKING

Package

The package is marked with:
 12-digit catalogue number;
 reference number of manufacturer;
 number of pieces.

Connector

The bodies of the male and female parts are marked with:
 12-digit catalogue number;
 type number;
 reference number of manufacturer;
 name of manufacturer.

The terminations are marked as shown in the table below.

Table 6

number of contacts	male part	female part
32 and 48 (style F)		
64 (style G)		

ACCESSORIES

The pins of the male part are snap-mounted in the body (Fig. 8a). They can be removed e.g. for relocating a protruding earth contact, by the contact release tool shown in Fig. 8b, catalogue number 4332 026 27200. A pin is removed by inserting the blade of the tool adjacent to the flat contact face of the pin and then removing the pin from the solder pin side of the connector. Due to the construction of the male part, if a pin is to be removed from row z, the corresponding pins must first be removed from rows b and d. If a pin is to be removed from row b, the corresponding pin must first be removed from row d; the pins can be removed from rows d and f independently. When replacing contact pins, the locking tine, which may have become compressed during contact removal, has to be restored to its original position. A tool is available for this purpose (Fig. 8c).

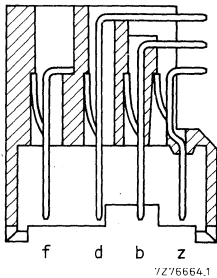

Fig. 8a Cross-section of male part.



Fig. 8b Contact release tool.

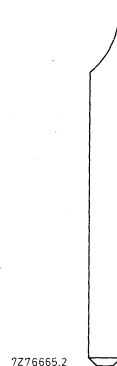

Fig. 8c Tool for restoring contact locking tine.

PACKING

The connectors are packed in boxes; male parts 10 per box, female parts 6 per box. Please order in multiples of these quantities.

3,81 mm (0,15 in) PITCH TWO-PART PRINTED-WIRING CONNECTORS

QUICK REFERENCE DATA

Contact pitch	3,81 mm (0,15 in)
Number of connections, double row test plug, double row	32, 42 8
Board thickness	1,42 to 1,78 mm
Terminations	
male part	pins for wire wrap
female part	solder tags
test plug	solder tags with eyelet
Current at $T_{amb} = 20\text{ }^{\circ}\text{C}$	2,5 A
Mechanical endurance	500 insertions
Climatic category (IEC68)	10/100/21

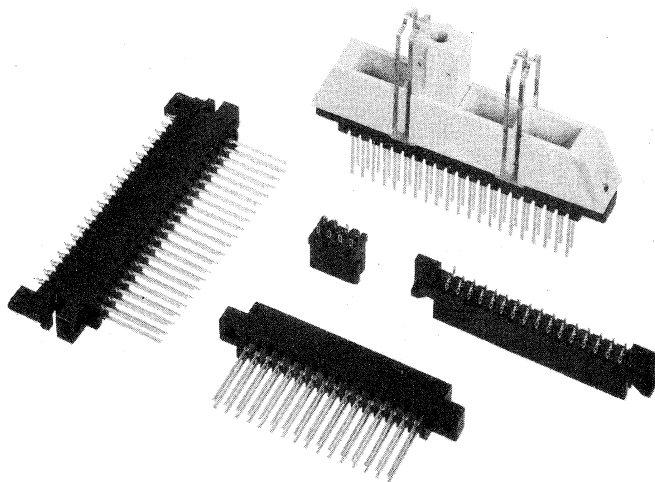

Contents

Application	2
Description	2
Electrical data	3
Mechanical data	4
Environmental data	5
Dimensional data	6
Mounting	8
Polarization and positioning	9
Marking	9
Accessories	10
Packing	12

APPLICATION

For use in telecommunication equipment.

DESCRIPTION

The connectors consist of a female part to be fitted to a printed-wiring board and a male part to be mounted on a chassis or a back panel. Both parts have a dark green glass-fibre-filled phenolformaldehyde body. The contact springs and contact pins are of phosphor bronze; the contact surfaces are rolled-on gold on nickel plating. The contact mating length is 3,5 mm min. The contacts are specially treated to prevent the influence of sparks on contact surfaces when printed-wiring boards are plugged into or pulled out of equipment in operation.

A test plug with 8 contacts is available for use as a cable connector for monitoring circuit parameters (see Accessories).

ELECTRICAL DATA

Current at $T_{amb} = 20\text{ }^{\circ}\text{C}$	2,5 A
Derated current curve	according to IEC512-3, test 5b, see Fig.1
Contact resistance (including material resistance) at 10 mA, max 20 mV (peak) open circuit voltage, 1 kHz.	
Measured outside the body:	
initially	$\leq 13\text{ m}\Omega$
after mechanical endurance	$\leq 13\text{ m}\Omega$
after damp heat test	$\leq 13\text{ m}\Omega$
Insulation resistance	
initially	$> 10^4\text{ M}\Omega$
after damp heat test	$> 10^3\text{ M}\Omega$
at maximum ambient temperature	$> 10^4\text{ M}\Omega$
Creepage distance	
between adjacent contacts	$\geq 0,7\text{ mm}$
between opposite contacts	$\geq 2,2\text{ mm}$
Clearance	
between adjacent contacts	$\geq 0,6\text{ mm}$
between opposite contacts	$\geq 1,4\text{ mm}$
Proof voltage for 1 min, at $20\text{ }^{\circ}\text{C}$	
between adjacent contacts	1200 V (r.m.s.), 50 Hz
between opposite contacts	2000 V (r.m.s.), 50 Hz
Capacitance between contacts at 1 kHz	$\leq 4\text{ pF}$

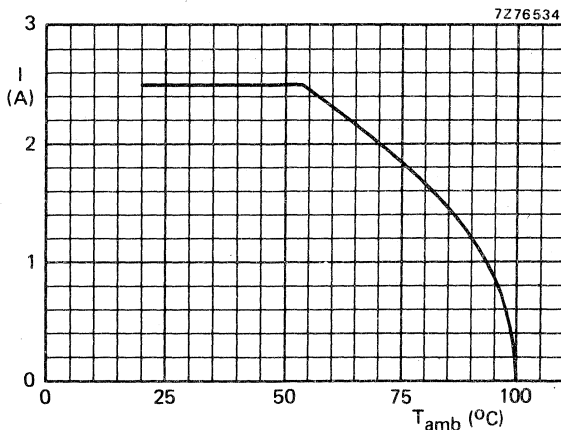

Fig.1 Maximum current per contact, equally on all contacts, as a function of ambient temperature.

MECHANICAL DATA

Contact pitch	3,81 mm (0,15 in)
Number of connections, double row	32, 42
Board thickness	1,42 to 1,78 mm
Polarization and positioning	by means of polarizing key pins
Insertion force	see Table 1
Withdrawal force	see Table 1
Mechanical endurance	500 insertions; according to IEC512-5, test 9a
Connector body material	glass-fibre-filled phenolformaldehyde
Contacts	
material	male part female part
shape	phosphor bronze phosphor bronze
finish of contact surfaces	solid cantilever bifurcated
	$\geq 2,5 \mu\text{m}$ rolled-on $\geq 2,5 \mu\text{m}$ rolled-on
	gold on $\geq 1 \mu\text{m}$ gold on $\geq 1 \mu\text{m}$
	nickel plate nickel plate
	$\geq 0,5 \text{ N}$
contact force	
type of termination	pin for wire wrap solder tag
finish of termination	$\geq 0,2 \mu\text{m}$ gold plate $\geq 0,2 \mu\text{m}$ gold plate
Contact retention in insert	
push	$\geq 20 \text{ N}$ $\geq 8 \text{ N}$
pull	$\geq 40 \text{ N}$ $\geq 20 \text{ N}$
Wire cross-section	AWG24 to AWG26 (ϕ 0,5 to ϕ 0,4 mm)
Mass	see Table 1
Solderability	235 °C, 2 s } according to IEC68, test T
Resistance to heat	260 °C, 10 s }
Bumping	according to IEC68, test Eb, 10g, 16 ms, 6 directions, 1000 bumps
Vibration	according to IEC68, test Fc, 10 to 55 Hz, 0,7 mm (p-p), 3 directions, 2 h per direction

Table 1

number of connections	insertion force (N)	withdrawal force (N)	approx. mass (g)	
			male part	female part
32	≤ 35	≥ 3	14,8	10,4
42	≤ 45	≥ 4	18,8	13,3

ENVIRONMENTAL DATA

Climatic category (IEC68)

10/100/21

Ambient temperature range

-10 to +100 °C

Storage temperature range

-40 to +100 °C

Damp heat, steady state

according to IEC68, test Ca, 21 days,
40 °C, R.H. 90 to 95%

Industrial atmosphere

0,05% H₂S, 24 h; 0,05% SO₂, 24 h

DIMENSIONAL DATA

Dimensions in mm

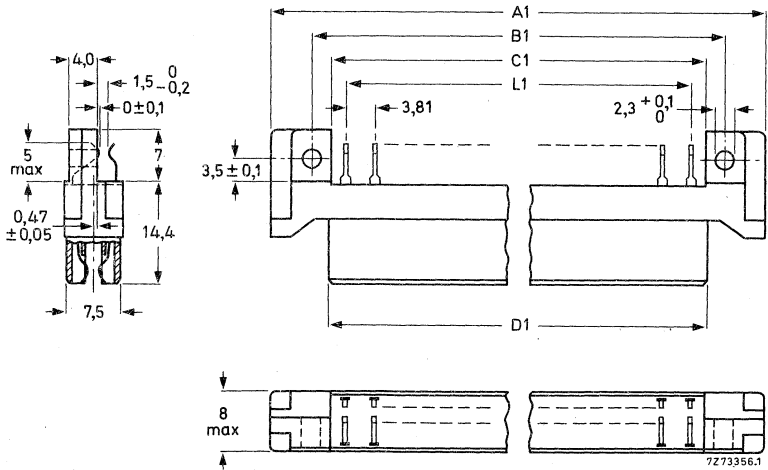

Fig.2 Female part; see Table 2 for dimensions A1, B1, C1, D1 and L1.

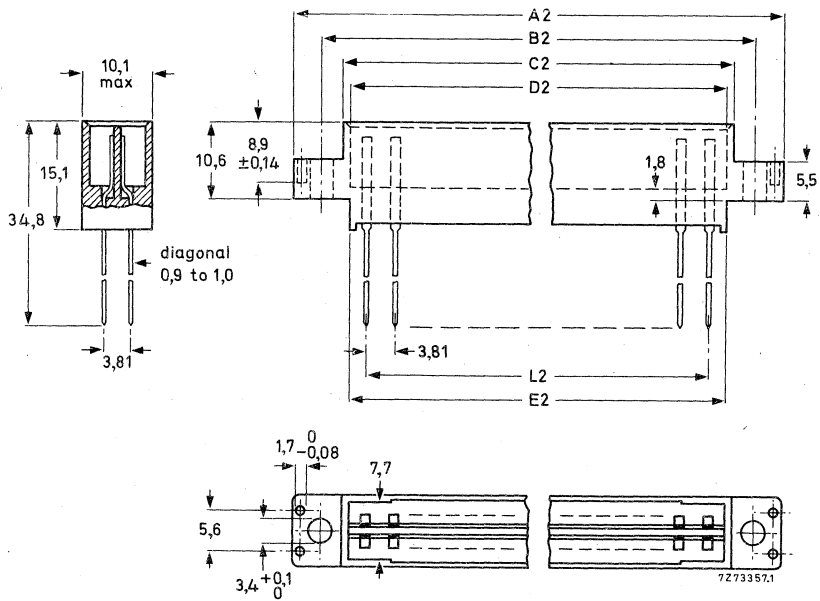

Fig.3 Male part; see Table 3 for dimensions A2, B2, C2, D2, E2 and L2.

Table 2

number of connections	dimensions (mm)					catalogue number
	A1 _{max}	B1	C1 _{min}	D1	L1	
32	79,83	68,58 ± 0,1	62,9	63,98	57,15	2422 050 16008
42	100,15	88,90 ± 0,1	83,2	84,30	76,20	2422 050 21008

Table 3

number of connections	dimensions (mm)						catalogue number
	A2 _{max}	B2	C2 _{max}	D2	E2 _{max}	L2	
32	80,38	72,18 ± 0,1	66,43	64,38	63,68	57,15	2422 050 16007
42	100,70	92,50 ± 0,1	86,75	84,70	84,00	76,20	2422 050 21007

MOUNTING

Panel cut-out for male parts

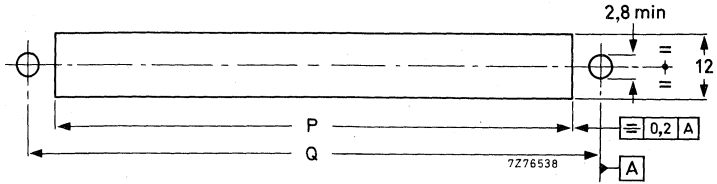

Fig.4 Panel cut-out for the male part; see Table 4 for dimensions P and Q.

Table 4

number of connections	dimensions (mm)	
	P	Q
32	65,20 ± 0,2	72,18 ± 0,2
42	85,50 ± 0,2	92,50 ± 0,2

Printed-wiring board recommendations

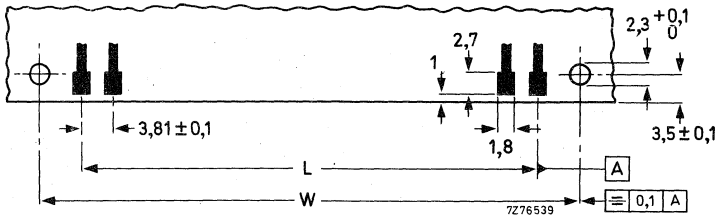

Fig.5 Recommended dimensions of the printed-wiring board to be fitted to the female part; see Table 5 for dimensions L and W.

Table 5

number of connections	dimensions (mm)	
	L	W
32	57,15	68,58 ± 0,1
42	76,20	88,90 ± 0,1

POLARIZATION AND POSITIONING

To ensure that a female part is inserted into the correct male part, key pins can be used, which have to be glued into the appropriate holes of the male part (Fig.6). The corresponding corners of the body of the matching female part have to be cut away (Fig.7).

It is recommended that two or more key pins be used and to distribute them over the two ears of the male part.

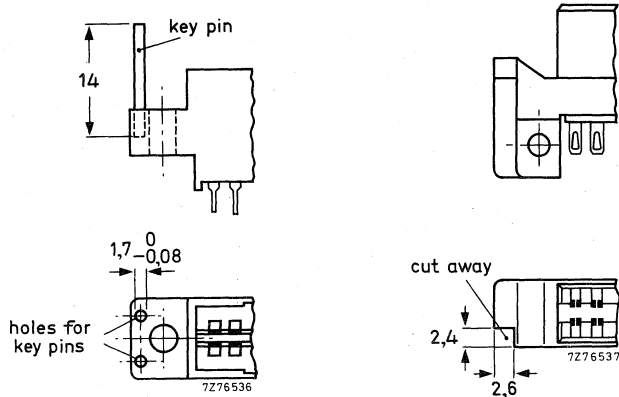

Fig.6

Fig.7

MARKING

The package is marked with:
12-digit catalogue number;
reference number of manufacturer;
number of pieces.

ACCESSORIES

A female test plug with 8 connections in double row can be supplied for use as a cable connector. In combination with the auxiliary parts shown in Fig.9, four test plugs mate with the male part with 42 connections.

The test plug has a dark green glass-fibre-filled phenolformaldehyde body. The bifurcated contact springs are of phosphor bronze; the contact surfaces are $2,5 \mu\text{m}$ min rolled-on gold on $1 \mu\text{m}$ min nickel plating. The contact terminations are solder tags with eyelet.

The mass is 2,5 g.

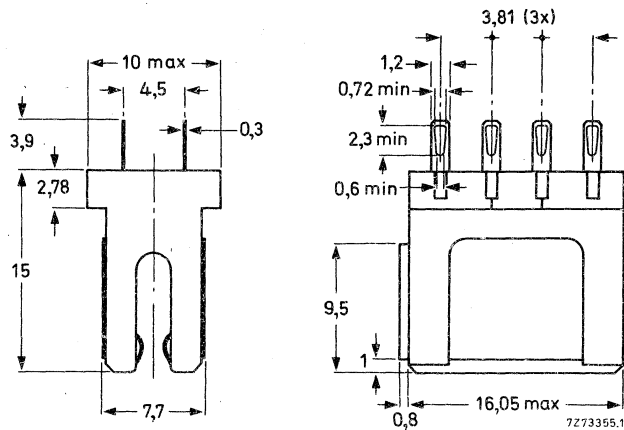

Fig.8 Test plug; dimensions in mm.

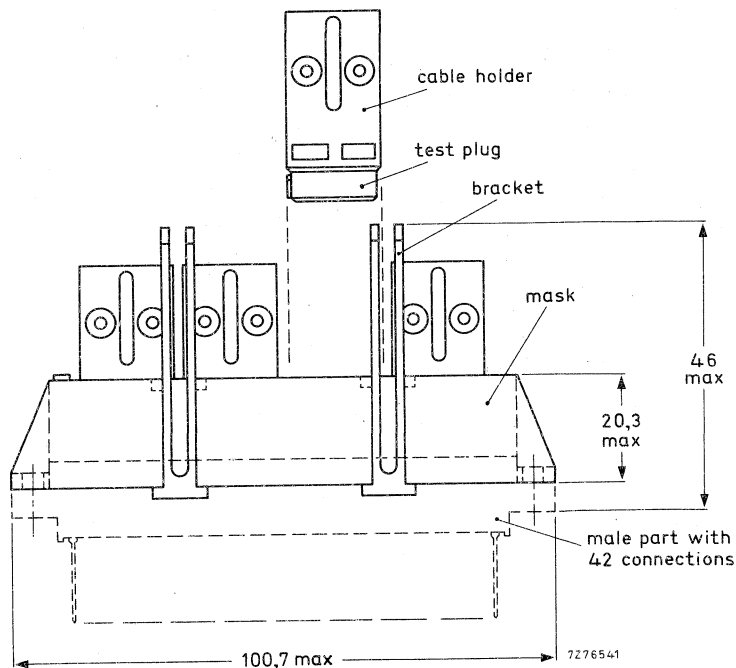

Fig.9 Four test plugs with auxiliary parts; dimensions in mm.

Catalogue numbers for ordering

Table 6

description	catalogue number
test plug	2422 050 90004
plastic cable holder	3522 202 15240
plastic mask	3522 202 15230
metal bracket	3522 202 08940

PACKING

The connectors and the test plug are packed in boxes. The number per box is given in Table 7.

Table 7

connector	number per box
male part, 32 connections	60
female part, 32 connections	60
male part, 42 connections	50
female part, 42 connections	50
test plug	88

Please order in multiples of these quantities.

2,54 mm (0,1 in) PITCH TWO-PART PRINTED-WIRING CONNECTORS

QUICK REFERENCE DATA

Contact pitch	2,54 mm (0,1 in)
Number of connections, double row	48, 64
test plug, double row	8
Board thickness	1,42 to 1,78 mm
Terminations	pins for wire wrap
male part	solder tags or solder tags with eyelet
female part	with eyelet (only for 48 connections)
test plug	solder tags with eyelet
Current at $T_{amb} = 20\text{ }^{\circ}\text{C}$	2 A
Mechanical endurance	500 insertions
Climatic category (IEC68)	10/100/21

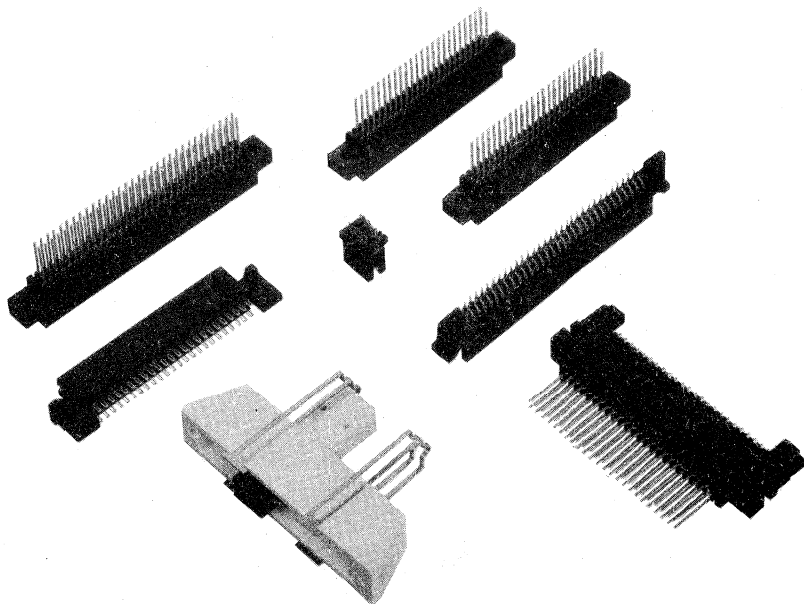

Contents

Application	2
Description	2
Electrical data	3
Mechanical data	4
Environmental data	5
Dimensional data	6
Mounting	8
Polarization and positioning	9
Marking	9
Accessories	10
Packing	12

APPLICATION

For use in telecommunication equipment.

DESCRIPTION

The connectors consist of a female part to be fitted to a printed-wiring board and a male part to be mounted on a chassis or a back panel. Both parts have a dark green glass-fibre-filled phenolformaldehyde body. The contact springs and contact pins are of phosphor bronze; the contact surfaces are rolled-on gold on nickel plating. The contact mating length is 3,5 mm min. The contacts are specially treated to prevent the influence of sparks on contact surfaces when printed-wiring boards are plugged into or pulled out of equipment in operation.

A test plug with 8 contacts is available for use as a cable connector for monitoring circuit parameters (see Accessories).

ELECTRICAL DATA

Current at $T_{amb} = 20\text{ }^{\circ}\text{C}$	2 A
Derated current curve	according to IEC512-3, test 5b, see Fig.1
Contact resistance (including material resistance) at 10 mA, max 20 mV (peak) open circuit voltage, 1 kHz.	
Measured outside the body:	
initially	$\leq 13\text{ m}\Omega$
after mechanical endurance	$\leq 13\text{ m}\Omega$
after damp heat test	$\leq 13\text{ m}\Omega$
Insulation resistance	
initially	$> 10^4\text{ M}\Omega$
after damp heat test	$> 10^3\text{ M}\Omega$
at maximum ambient temperature	$> 10^4\text{ M}\Omega$
Creepage distance	
between adjacent contacts	$\geq 0,5\text{ mm}$
between opposite contacts	$\geq 2,2\text{ mm}$
Clearance	
between adjacent contacts	$\geq 0,4\text{ mm}$
between opposite contacts	$\geq 1,4\text{ mm}$
Proof voltage for 1 min, at $20\text{ }^{\circ}\text{C}$	
between adjacent contacts	1000 V (r.m.s.), 50 Hz
between opposite contacts	2000 V (r.m.s.), 50 Hz
Capacitance between contacts at 1 kHz	$\leq 4\text{ pF}$

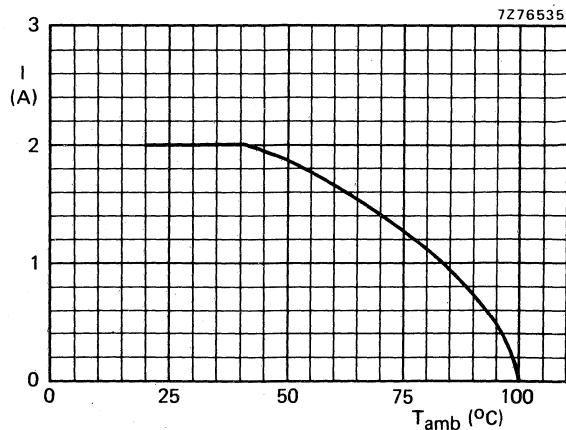

Fig.1 Maximum current per contact, equally on all contacts, as a function of ambient temperature.

MECHANICAL DATA

Contact pitch	2,54 mm (0,1 in)
Number of connections, double row	48, 64
Board thickness	1,42 to 1,78 mm
Polarization and positioning	by means of polarizing key pins
Insertion force	see Table 1
Withdrawal force	see Table 1
Mechanical endurance	500 insertions; according to IEC512-5, test 9a
Connector body material	glass-fibre-filled phenolformaldehyde
Contacts	male part female part
material	phosphor bronze phosphor bronze
shape	solid cantilever bifurcated
finish of contact surfaces	$\geq 2,5 \mu\text{m}$ rolled-on gold on $\geq 1 \mu\text{m}$ nickel plate $\geq 2,5 \mu\text{m}$ rolled-on gold on $\geq 1 \mu\text{m}$ nickel plate
contact force	$\geq 0,5 \text{ N}$
type of termination	
48 connections	pin for wire wrap solder tag, solder tag with eyelet
64 connections	pin for wire wrap solder tag
finish of termination	$\geq 0,2 \mu\text{m}$ gold plate $\geq 0,2 \mu\text{m}$ gold plate
Contact retention in insert	
push	$\geq 20 \text{ N}$ $\geq 8 \text{ N}$
pull	$\geq 40 \text{ N}$ $\geq 20 \text{ N}$
Wire cross-section	AWG24 to AWG26 (ϕ 0,5 to ϕ 0,4 mm)
Mass	see Table 1
Solderability	235 °C, 2 s
Resistance to heat	260 °C, 10 s } according to IEC 68, test T
Bumping	according to IEC 68, test Eb, 10g, 16 ms, 6 directions, 1000 bumps
Vibration	according to IEC 68, test Fc, 10 to 55 Hz, 0,7 mm (p-p), 3 directions, 2 h per direction

Table 1

number of connections	insertion force (N)	withdrawal force (N)	approx. mass (g)	
			male part	female part
48	≤ 50	≥ 5	15,9	10,5
64	≤ 65	≥ 7	20,4	13,2

ENVIRONMENTAL DATA

Climatic category (IEC 68)

10/100/21

Ambient temperature range

-10 to +100 °C

Storage temperature range

-40 to +100 °C

Damp heat, steady state

according to IEC 68, test Ca, 21 days,
40 °C, R.H. 90 to 95%

Industrial atmosphere

0,05% H₂S, 24 h; 0,05% SO₂, 24 h

DIMENSIONAL DATA

Dimensions in mm

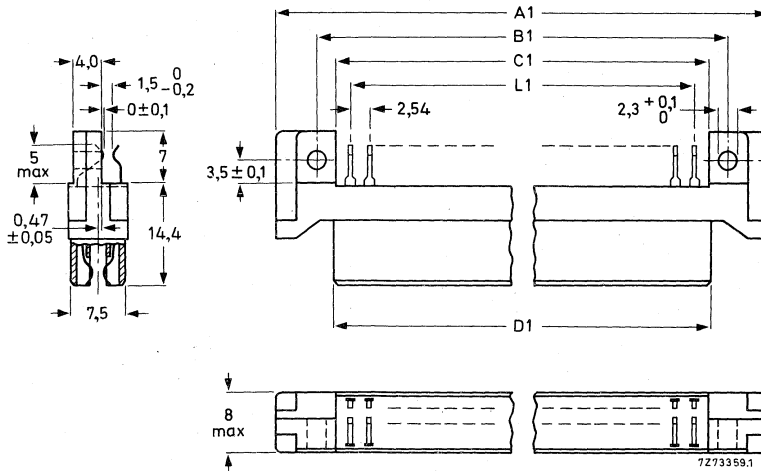

Fig.2 Female part with solder tags; see Table 2 for dimensions A1, B1, C1, D1 and L1.

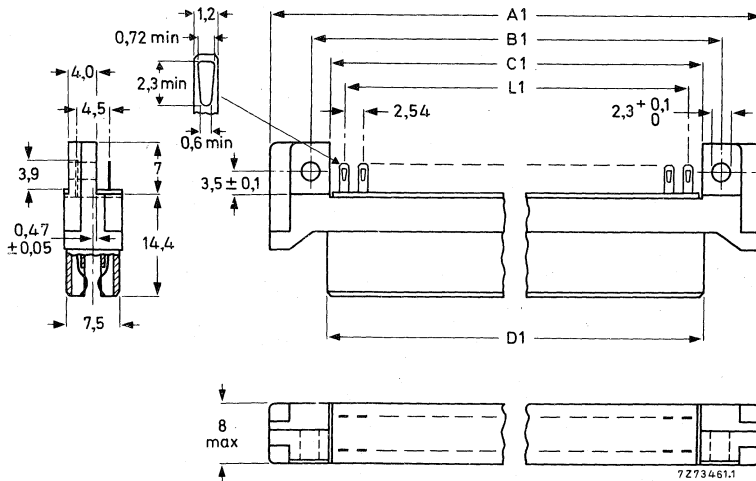

Fig.3 Female part with solder tags with eyelet; see Table 2 for dimensions A1, B1, C1, D1 and L1.

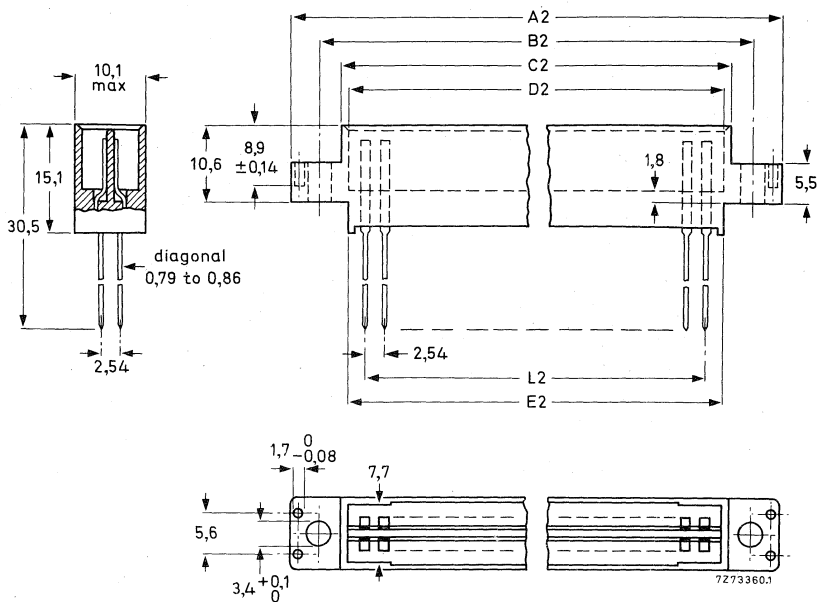

Fig.4 Male part; see Table 3. for dimensions A2, B2, C2, D2, E2 and L2.

Table 2

number of connections	dimensions (mm)					catalogue number
	A1 _{max}	B1	C1 _{min}	D1	L1	
48 (Fig.2)	79,83	68,58 ± 0,1	62,9	63,98	58,42	2422 049 24008
48 (Fig.3)	79,83	68,58 ± 0,1	62,9	63,98	58,42	2422 049 24018
64 (Fig.2)	100,15	88,90 ± 0,1	83,2	84,30	78,74	2422 049 32008

Table 3

number of connections	dimensions (mm)						catalogue number
	A2 _{max}	B2	C2 _{max}	D2	E2 _{max}	L2	
48	80,38	72,18 ± 0,1	66,43	64,38	63,68	58,42	2422 049 24007
64	100,70	92,50 ± 0,1	86,75	84,70	84,00	78,74	2422 049 32007

MOUNTING

Panel cut-out for male parts

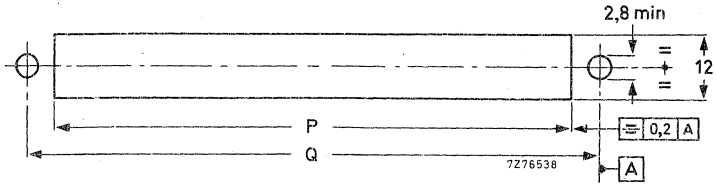

Fig.5 Panel cut-out for the male part; see Table 4 for dimensions P and Q.

Table 4

number of connections	dimensions (mm)	
	P	Q
48	65,20 ± 0,2	72,18 ± 0,2
64	85,50 ± 0,2	92,50 ± 0,2

Printed-wiring board recommendations

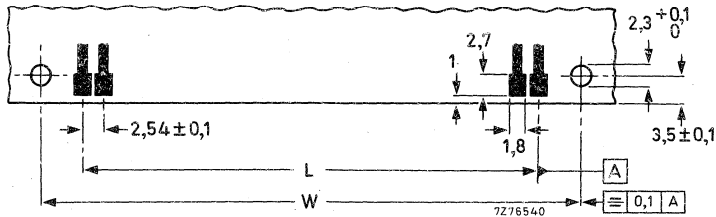

Fig.6 Recommended dimensions of the printed-wiring board to be fitted to the female part; see Table 5 for dimensions L and W.

Table 5

number of connections	dimensions (mm)	
	L	W
48	58,42	68,58 ± 0,1
64	78,74	88,90 ± 0,1

POLARIZATION AND POSITIONING

To ensure that a female part is inserted into the correct male part, key pins can be used, which have to be glued into the appropriate holes of the male part (Fig.7). The corresponding corners of the body of the matching female part have to be cut away (Fig.8).

It is recommended that two or more key pins be used and to distribute them over the two ears of the male part.

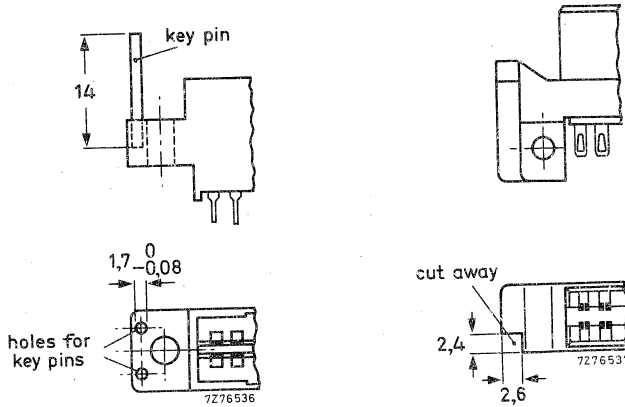

Fig.7

Fig.8

MARKING

The package is marked with:
12-digit catalogue number;
reference number of manufacturer;
number of pieces.

ACCESSORIES

A female test plug with 8 connections in double row can be supplied for use as a cable connector. In combination with the auxiliary parts shown in Fig.10, four test plugs mate with the male part with 48 connections.

The test plug has a dark green glass-fibre-filled phenolformaldehyde body. The bifurcated contact springs are of phosphor bronze; the contact surfaces are 2,5 μm min rolled-on gold on 1 μm min nickel plating. The contact terminations are solder tags with eyelet.

The mass is 1,9 g.

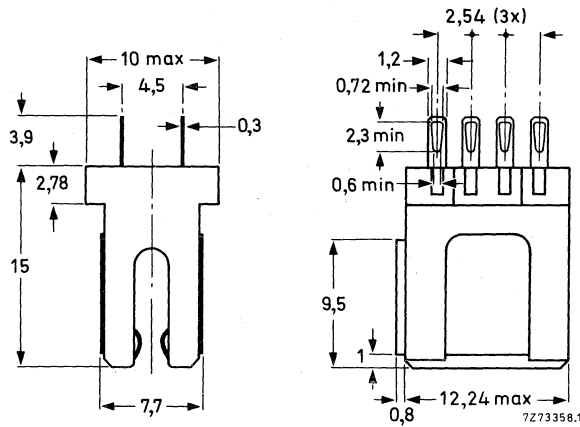

Fig.9 Test plug; dimensions in mm.

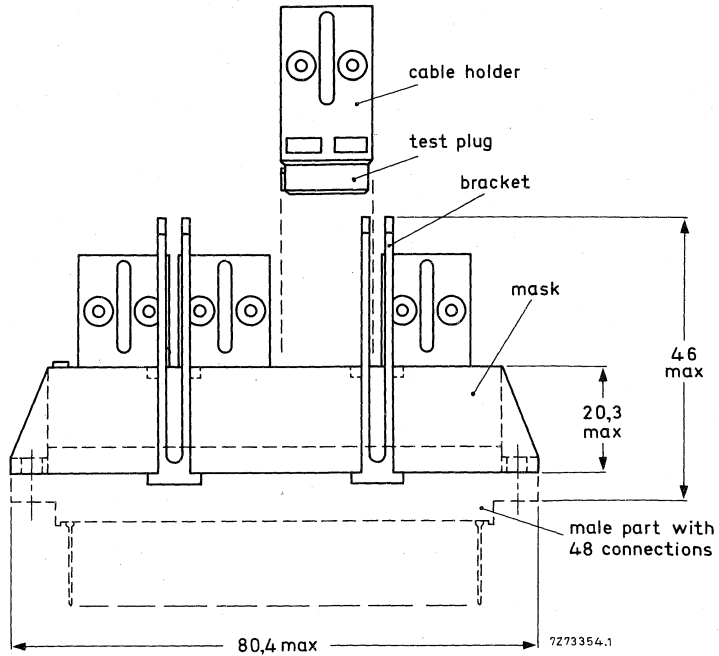

Fig.10 Four test plugs with auxiliary parts; dimensions in mm.

Catalogue numbers for ordering

Table 6

description	catalogue number
test plug	2422 049 90004
plastic cable holder	3522 202 15240
plastic mask	3522 202 15230
metal bracket	3522 202 08940

PACKING

The connectors and the test plug are packed in boxes. The number per box is given in Table 7.

Table 7

connector	number per box
male part, 48 connections	60
female part, 48 connections	60
male part, 64 connections	50
female part, 64 connections	50
test plug	110

Please order in multiples of these quantities.

TWO-PART JUMPER CONNECTOR

- 2,54 mm (0,1 in) pitch

QUICK REFERENCE DATA

Contact pitch	2,54 mm (0,1 in)
Number of contacts	2
Board thickness	1,42 to 1,78 mm
Terminations of contact pins	suitable for dip-soldering
Current at $T_{amb} = 20\text{ }^{\circ}\text{C}$	3 A
Mechanical endurance	150 insertions
Climatic category (IEC 68)	55/125/21

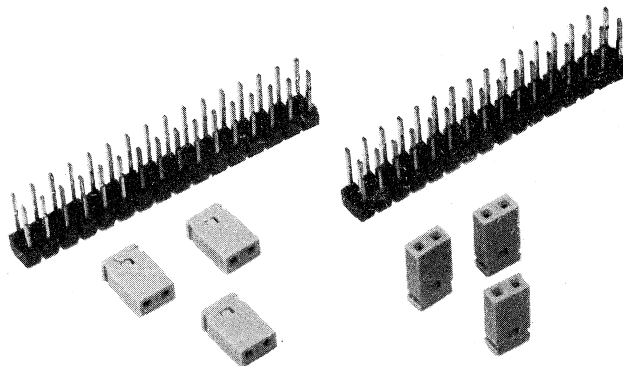

APPLICATION

This connector is intended for use as a link between two adjacent points on a printed-wiring board with a grid of 2,54 mm (0,1 in) thus enabling various circuit configurations to be built up or parts of the circuit to be shorted out.

DESCRIPTION

The connector consists of two contact pins for dip-solder mounting and a female plug. The plug is moulded in grey glass-fibre-filled thermoplastic. The contact springs in the plug and the pins are of phosphor bronze; the springs are shaped to provide two contact surfaces.

The contact faces are hard gold plated. The pins can be supplied either loose or in a mounting strip with 2 x 16 pins which can be removed after dip-soldering.

If the contact pins are to be permanently interconnected, a modified wire wrapping can be used instead of the female plug.

ELECTRICAL DATA

Current at $T_{amb} = 20\text{ }^{\circ}\text{C}$	3 A
Derated current curve	according to IEC 512-3, test 5b, see Fig. 1
<p>Contact resistance (including material resistance) at 10 mA, max. 20 mV (peak) open circuit voltage, 1 kHz.</p> <p>Measured at point A, see Fig. 2</p> <ul style="list-style-type: none"> initially $\leq 25\text{ m}\Omega$ after mechanical endurance $\leq 25\text{ m}\Omega$ after damp heat test $\leq 35\text{ m}\Omega$ 	
<p>Insulation resistance</p> <ul style="list-style-type: none"> initially $> 5 \cdot 10^3\text{ M}\Omega$ after damp heat test $> 10^3\text{ M}\Omega$ 	
<p>Proof voltage for 1 min, at $20\text{ }^{\circ}\text{C}$</p> <ul style="list-style-type: none"> between contact and a metal mounting plate 1000 V (r.m.s.), 50 Hz 	

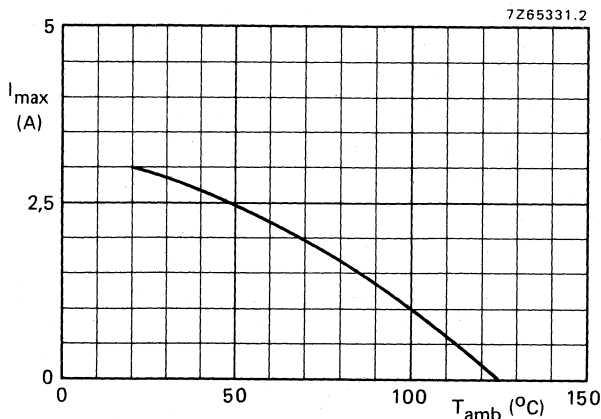

Fig. 1 Maximum current per contact, equally on all contacts, as a function of ambient temperature (20% derated).

MECHANICAL DATA

Contact pitch	2,54 mm (0,1 in)
Number of contacts	2
Board thickness	1,42 to 1,78 mm
Insertion force	≤ 2N
Withdrawal force	≥ 0,12N
Mechanical endurance	150 insertions; according to IEC 512-5, test 9a
Connector body material	glass-fibre-filled thermoplastic
Contact pins and springs material	phosphor bronze
shape	see Fig. 2
finish of contact surfaces	≥ 1 μm hard gold
contact force	≥ 2 x 0,5N
type of pin termination	dip-solder
finish of termination	≥ 1 μm hard gold
Mass	
female plug	0,16g
contact pin	0,021g
Solderability	according to IEC 68, test T, 350 °C, 2 s
Shock	according to IEC 68, test Ea, 50g, 11 ms (plug in fixed position)
Vibration	according to IEC 68, test Fc. 10 to 1500 Hz, 1,5 mm (p-p) or 10g, 3 directions, 2 h per direction (plug in fixed position)

ENVIRONMENTAL DATA

Climatic category (IEC 68)	55/125/21
Ambient temperature range	-55 to + 125 °C
Damp heat, steady state	according to IEC 68, test Ca, 21 days, 40 °C, R.H. 90 to 95%
Flammability	according to UL94, category V1

DIMENSIONAL DATA

Dimensions in mm

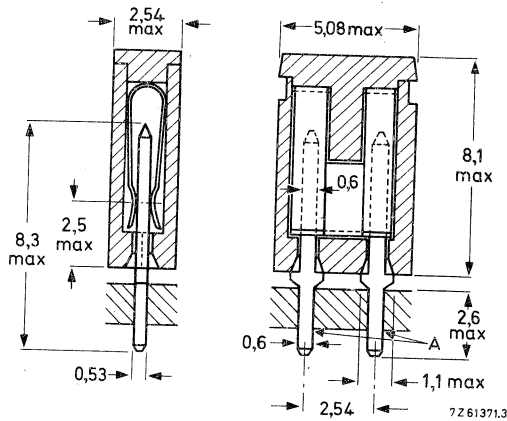

Fig. 2 Two-part jumper connector in mounted position.

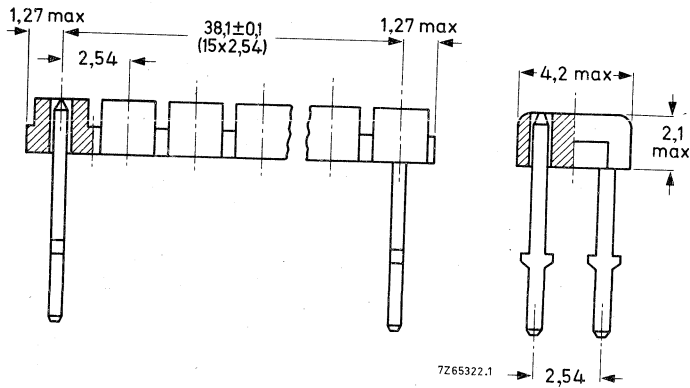

Fig. 3 Removable mounting strip with 2 x 16 contact pins. For pin dimensions see Fig. 2.

Table 1—Catalogue numbers for ordering.

connector part	catalogue number
female plug	2422 024 88003
loose pin	4332 026 16770
removable mounting strip with 2 x 16 pins	2422 025 89303

MOUNTING

The best result of pin positioning is achieved by using pins supplied on a removable mounting strip. After dip or wave soldering of the pins, the strip can be removed by hand or a pair of tweezers. For piercing diagram of the printed-wiring board see Fig. 4.

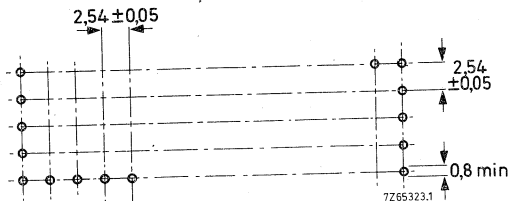

Fig. 4 Piercing diagram.

MARKING

The package is marked with:
 12-digit catalogue number;
 reference number of manufacturer;
 number of pieces.

PACKING

The female plugs and the loose pins are packed in plastic bags: plugs 500 per bag, pins 1000 per bag. Mounting strips with 2×16 contact pins are packed in boxes of 30. Please order in multiples of these quantities.

MODULAR CONNECTOR SYSTEM

- For basic grid of 2,54 mm (0,1 in)

QUICK REFERENCE DATA

Contact pitch	2,54 mm (0,1 in)
Number of contacts	
<i>Female connectors</i>	
board edge socket, single row	2 to 32
board edge socket, double row	4 to 130
panel socket, single row	2 to 32
panel socket, double row	4 to 100
cable connector, double row	4 to 64
<i>Male connectors</i>	
male header, straight pins, single row	2 to 32
male header, straight pins, double row	4 to 64
mounting block for pins, double row	8, 12, 20
male header, 90° angled pins, single row	15
male header, 90° angled pins, double row	30
Board thickness	1,42 to 1,78 mm
Terminations	dip-solder pins pins for wire wrapping crimp contacts
Current at $T_{amb} = 20\text{ °C}$	3 A
Mechanical endurance	300 insertions
Climatic category (IEC 68)	55/125/21

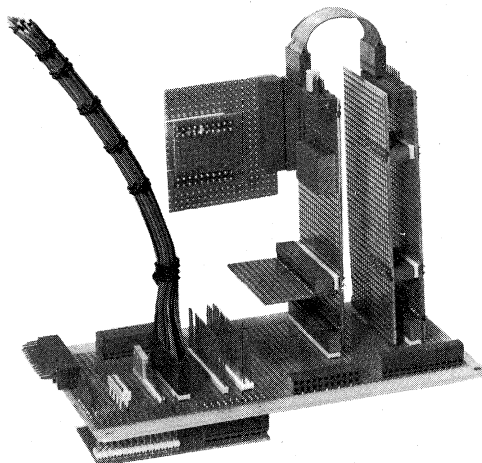

APPLICATION

This modular connector system has been developed to provide a simple, flexible yet reliable means of interconnecting electronic circuit boards and modules in applications where maximum packing density is of major importance.

DESCRIPTION

The system consists of the following parts (see also Fig. 1).

Female connectors:

- board edge sockets for connecting daughter boards at right-angles to mother boards in vertically stacked card systems;
- panel sockets for horizontally stacking printed-wiring boards;
- cable connectors for connecting cable forms to printed-wiring boards or for making multi-way jumper cables.

Male connectors:

- male headers with straight or 90° angled pins for accommodating mini wire wrapping joints or mating panel sockets and board edge sockets;
- mounting block for pins, which can be removed after mounting if required.

The board edge sockets, panel sockets and cable connectors have a body of flame retardent, glass-fibre-filled thermosetting material. The sockets are provided with pins for dip or wave soldering. The cable connectors contain a number of holes allowing crimpable contact springs to be inserted into the body. These crimp-on snap-in contact springs are supplied loose or on reels.

The male headers and the mounting blocks have a body of flame retardent, glass-fibre-filled thermoplastic polyester material. They are provided with dip-solder pins or pins for wire wrapping.

The contact springs and pins are of gold finished phosphor bronze; the electrical contact surfaces are gold on nickel plating.

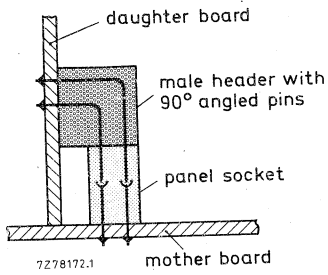

Fig. 1a.

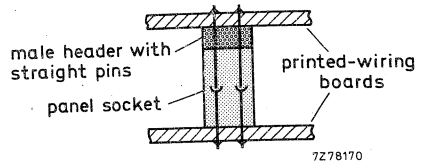

Fig. 1b.

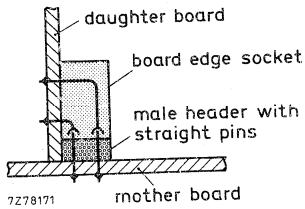

Fig. 1c.

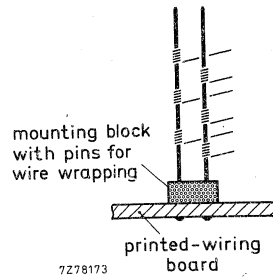

Fig. 1d.

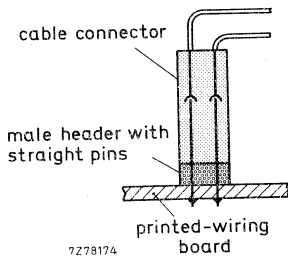

Fig. 1e.

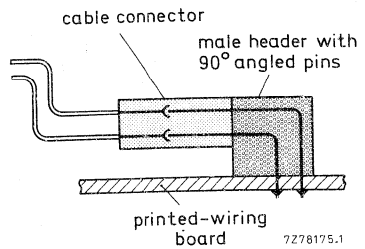

Fig. 1f.

ELECTRICAL DATA

Current at $T_{amb} = 20\text{ }^{\circ}\text{C}$

3 A

Derated current curve

according to IEC 512-3,
test 5b, see Fig. 2

Contact resistance (including material resistance) at 10 mA, max. 20 mV (peak)

open circuit voltage, 1 kHz.

Measured on contact pin at 2 mm

from connector body:

initially

$\leq 15\text{ m}\Omega$

after mechanical endurance

$\leq 20\text{ m}\Omega$

after damp heat test

$\leq 20\text{ m}\Omega$

Insulation resistance

initially

$> 10^5\text{ M}\Omega$

after damp heat test

$> 10^3\text{ M}\Omega$

at maximum ambient temperature

$> 10^3\text{ M}\Omega$

Creepage distance

between adjacent or opposite contacts

$\geq 0,5\text{ mm}$

Clearance

between adjacent or opposite contacts

$\geq 0,4\text{ mm}$

Proof voltage for 1 min, at $20\text{ }^{\circ}\text{C}$

between adjacent or opposite contacts

750 V (r.m.s.), 50 Hz

Capacitance between contacts at 1 MHz

$\leq 1,5\text{ pF}$

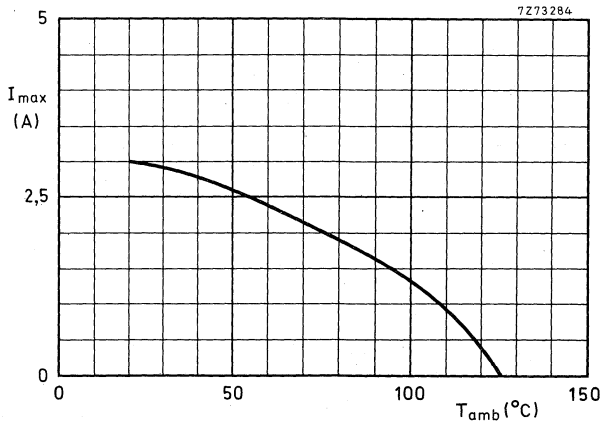

Fig. 2 Maximum current per contact, equally on all contacts, as a function of ambient temperature (20% derated).

MECHANICAL DATA

Contact pitch	2,54 mm (0,1 in)	
Number of contacts		
<i>Female connectors</i>		
board edge socket, single row	2 to 32	
board edge socket, double row	4 to 130	
panel socket, single row	2 to 32	
panel socket, double row	4 to 100	
cable connector, double row	4 to 64	
<i>Male connectors</i>		
male header, straight pins, single row	2 to 32	
male header, straight pins, double row	4 to 64	
mounting block for pins, double row	8, 12, 20	
male header, 90° angled pins, single row	15	
male header, 90° angled pins, double row	30	
Board thickness (for dip-solder application)	1,42 to 1,78 mm	
Insertion force per contact	≤ 1,5 N	
Withdrawal force per contact	≥ 0,1 N	
Mechanical endurance	300 insertions: according to IEC 512-5, test 9a	
Connector body material	glass-fibre-filled thermosetting glass-fibre-filled thermoplastic	
board edge socket, panel socket and cable connector		
male headers and mounting block		
Contacts		
material	phosphor bronze	phosphor bronze
shape	solid cantilever	square wire, chamfered at both ends
finish of contact surfaces	≥ 2,4 μm rolled-on gold on ≥ 1 μm nickel plate	≥ 1 μm gold plate on ≥ 1 μm nickel plate
type of termination	dip-solder pin crimp contact	dip-solder pin pin for wire wrapping
finish of termination	≥ 0,15 μm gold flash	≥ 1 μm gold plate on ≥ 1 μm nickel plate
Wire diameter		
for crimp contacts	AWG30 to AWG24 (φ0,25 to 0,50 mm)	
for wire wrapping	AWG30 to AWG28 (φ0,25 to 0,32 mm)	
Solderability	230 °C, 2 s	} according to IEC 68, test T
Resistance to soldering heat	350 °C, 3,5 s	
Shock	according to IEC 68, test Ea, 50g, 11 ms	
Vibration	according to IEC 68, test Fc, 10 to 2000 Hz, 1,5 mm (p-p) or 10g, 3 directions, 2 h per direction	

ENVIRONMENTAL DATA

Climatic category (IEC 68)

Ambient temperature range

Storage temperature range

Damp heat, steady state

Dry heat

Salt mist

Flammability

55/125/21

-55 to + 125 °C

-55 to + 125 °C

according to IEC 68, test Ca,
21 days, 40 °C, R.H. 90 to 95%according to IEC 68, test Ba,
16 h, 125 °Caccording to IEC 68, test Ka,
96 h

according to UL94, category V0

DIMENSIONAL DATA

Dimensions in mm

Board edge sockets

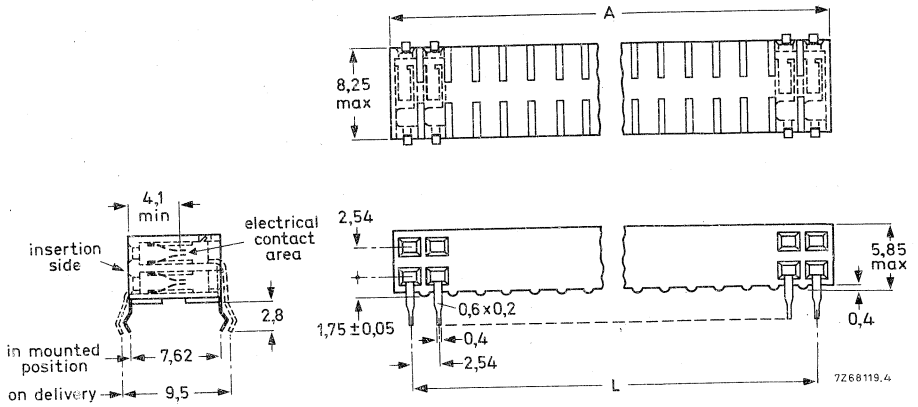

Fig. 3 Board edge socket, double row. See Table 1 for dimensions A and L.

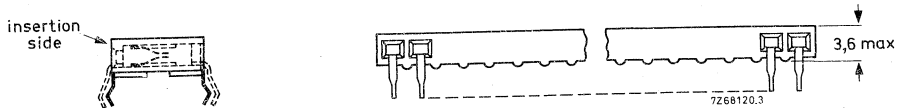

Fig. 4 Board edge socket, single row. Dimensions are identical with those in Fig. 3, except as shown.

Table 1

number of contacts		L	A	catalogue number	
single row	double row			single row	double row
2	4	2,54	5,44	2422 062 10202	2422 062 10212
3	6	5,08	7,98	10302	10312
4	8	7,62	10,52	10402	10412
5	10	10,16	13,06	10502	10512
6	12	12,70	15,60	10602	10612
7	14	15,24	18,14	10702	10712
8	16	17,78	20,68	10802	10812
9	18	20,32	23,22	10902	10912
10	20	22,86	25,76	11002	11012
11	22	25,40	28,30	11102	11112
12	24	27,94	30,84	11202	11212
13	26	30,48	33,38	11302	11312
14	28	33,02	35,92	11402	11412
15	30	35,56	38,46	11502	11512
16	32	38,10	41,00	11602	11612
17	34	40,64	43,54	11702	11712
18	36	43,18	46,08	11802	11812
19	38	45,72	48,62	11902	11912
20	40	48,26	51,16	12002	12012
21	42	50,80	53,70	12102	12112
22	44	53,34	56,24	12202	12212
23	46	55,88	58,78	12302	12312
24	48	58,42	61,32	12402	12412
25	50	60,96	63,86	12502	12512
26	52	63,50	66,40	12602	12612
27	54	66,04	68,94	12702	12712
28	56	68,58	71,48	12802	12812
29	58	71,12	74,02	12902	12912
30	60	73,66	76,56	13002	13012
31	62	76,20	79,10	13102	13112
32	64	78,74	81,64	13202	13212

Table 1 (continued)

number of contacts		L	A	catalogue number	
single row	double row			single row	double row
	66	81,28	84,18		2422 062 13312
	68	83,82	86,72		13412
	70	86,36	89,26		13512
	72	88,90	91,80		13612
	74	91,44	94,34		13712
	76	93,98	96,88		13812
	78	96,52	99,42		13912
	80	99,06	101,96		14012
	82	101,60	104,50		14112
	84	104,14	107,04		14212
	86	106,68	109,58		14312
	88	109,22	112,12		14412
	90	111,76	114,66		14512
	92	114,30	117,20		14612
	94	116,84	119,74		14712
	96	119,38	122,28		14812
	98	121,92	124,82	$\pm 0,30$	14912
	100	124,46	127,36	$\pm 0,15$	15012
	102	127,00	129,90		15112
	104	129,54	132,44		15212
	106	132,08	134,98		15312
	108	134,62	137,52		15412
	110	137,16	140,06		15512
	112	139,70	142,60		15612
	114	142,24	145,14		15712
	116	144,78	147,68		15812
	118	147,32	150,22		15912
	120	149,86	152,76		16012
	122	152,40	155,30		16112
	124	154,94	157,84		16212
	126	157,48	160,38		16312
	128	160,02	162,92		16412
	130	162,56	165,46		16512

Panel sockets

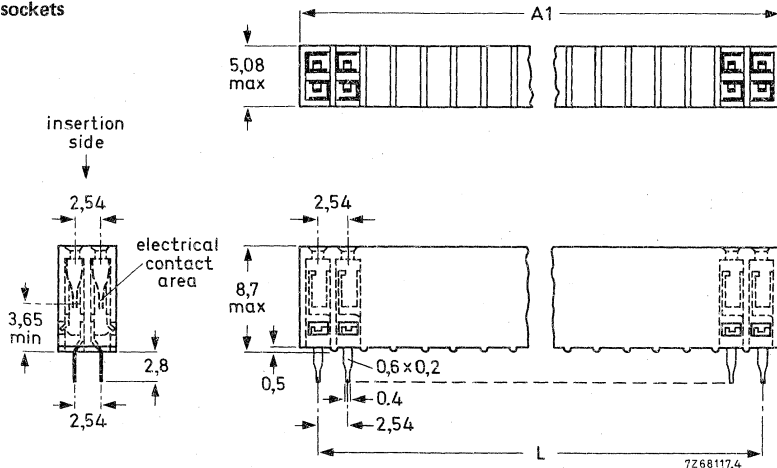

Fig. 5 Panel socket, double row. See Table 2 for dimensions A1 and L.

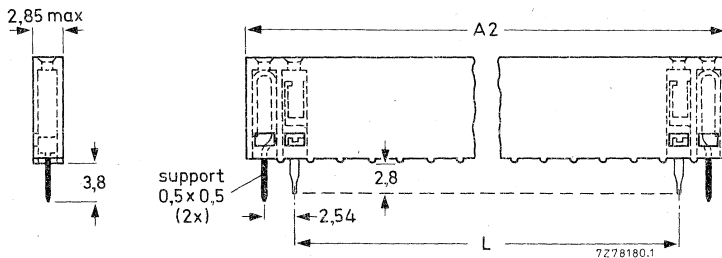

Fig. 6 Panel socket, single row. Dimensions are identical with those in Fig. 5 except as shown. See Table 2 for dimensions A2 and L.

Table 2

number of contacts		L	A1	A2	catalogue number	
single row	double row				single row (with supports)	double row (without supports)
2	4	2,54	5,44	10,52	2422 062 00272	2422 062 00212
3	6	5,08	7,98	13,06	00372	00312
4	8	7,62	10,52	15,60	00472	00412
5	10	10,16	13,06	18,14	00572	00512
6	12	12,70	15,60	20,68	00672	00612
7	14	15,24	18,14	23,22	00772	00712
8	16	17,78	20,68	25,76	00872	00812
9	18	20,32	23,22	28,30	00972	00912
10	20	22,86	25,76	30,84	01072	01012

Table 2 (continued)

number of contacts		L	A1	A2	catalogue number			
single row	double row				single row (with supports)	double row (without supports)		
11	22	25,40	28,30	33,38	±0,30	2422 062 01172	2422 062 01112	
12	24	27,94	30,84	35,92		01272	01212	
13	26	30,48	33,38	38,46		01372	01312	
14	28	33,02	35,92	41,00		01472	01412	
15	30	35,56	38,46	43,54		01572	01512	
16	32	38,10	41,00	46,08		01672	01612	
17	34	40,64	43,54	48,62		01772	01712	
18	36	43,18	46,08	51,16		01872	01812	
19	38	45,72	48,62	53,70		01972	01912	
20	40	48,26	51,16	56,24		02072	02012	
21	42	50,80	53,70	58,78		02172	02112	
22	44	53,34	56,24	61,32		02272	02212	
23	46	55,88	58,78	63,86		02372	02312	
24	48	58,42	61,32	66,40		02472	02412	
25	50	60,96	63,86	68,94		02572	02512	
26	52	63,50	66,40	71,48		02672	02612	
27	54	66,04	68,94	74,02		02772	02712	
28	56	68,58	71,48	76,56		02872	02812	
29	58	71,12	74,02	79,10		02972	02912	
30	60	73,66	76,56	81,64		03072	03012	
31	62	76,20	79,10	84,18		±0,30	03172	03112
32	64	78,74	81,64	86,72			03272	03212
	66	81,28	84,18					03312
	68	83,82	86,72					03412
	70	86,36	89,26					03512
	72	88,90	91,80					03612
	74	91,44	94,34					03712
	76	93,98	96,88					03812
	78	96,52	99,42					03912
	80	99,06	101,96					04012
	82	101,60	104,50				04112	
	84	104,14	107,04				04212	
	86	106,68	109,58				04312	
	88	109,22	112,12				04412	
	90	111,76	114,66				04512	
	92	114,30	117,20				04612	
	94	116,84	119,74				04712	
	96	119,38	122,28			04812		
	98	121,92	124,82			04912		
	100	124,46	127,36			05012		

Cable connector

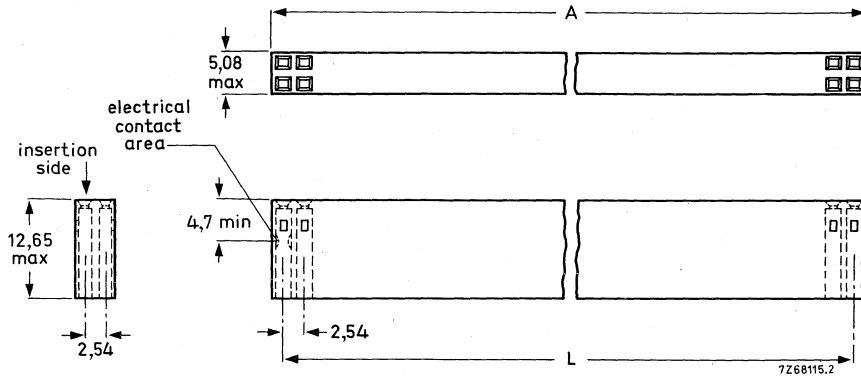

Fig. 7 Cable connector, double row; see Table 3 for dimensions A and L.

Note

The cable connector housing and the crimp contact springs are supplied separately; crimp contact springs are available loose or on reels containing approx. 8000 pieces.

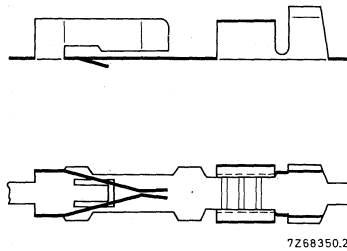

Fig. 8 Crimp-on snap-in contact spring.

Table 3

number of contacts double row	L	A	catalogue number of cable connector housing
4	2,54	5,44	4322 027 74020
6	5,08	7,98	74030
8	7,62	10,52	74040
10	10,16	13,06	74050
12	12,70	15,60	74060
14	15,24	18,14	74070
16	17,78	20,68	74080
18	20,32	23,22	74090
20	22,86	25,76	74100
22	25,40	28,30	74110
24	27,94	30,84	74120
26	30,48	33,38	74130
28	33,02	35,92	74140
30	35,56	38,46	74150
32	38,10	41,00	74160
34	40,64	43,54	74170
36	43,18	46,08	74180
38	45,72	48,62	74190
40	48,26	51,16	74200
42	50,80	53,70	74210
44	53,34	56,24	74220
46	55,88	58,78	74230
48	58,42	61,32	74240
50	60,96	63,86	74250
52	63,50	66,40	74260
54	66,04	68,94	74270
56	68,58	71,48	74280
58	71,12	74,02	74290
60	73,66	76,56	74300
62	76,20	79,10	74310
64	78,74	81,64	74320

Catalogue number of crimp contact springs

for hand-tool application, supplied loose in bags of 100 pieces: 4322 027 59850;

for machine application, supplied on reels of approx. 8000 pieces: 4322 027 59860.

Male header with straight pins

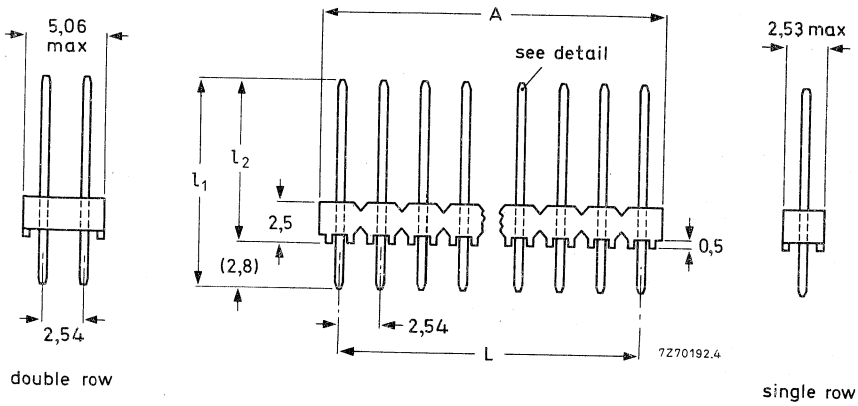

Fig. 9 Male header with straight pins. See Table 4 for dimensions A and L.
 Available pin lengths:
 $l_1 = 12 \pm 0,1$ mm, $l_2 = 9,2 \pm 0,2$ mm;
 $l_1 = 22 \pm 0,1$ mm, $l_2 = 19,2 \pm 0,2$ mm.
 Other pin lengths are available on request.

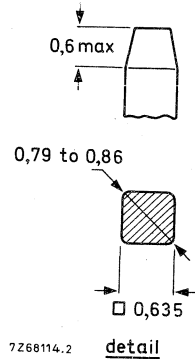

Table 4

number of contacts		L	A	catalogue number 2422 062			
				pin length $l_1 = 12$ mm		pin length $l_1 = 22$ mm	
single row	double row			single row	double row	single row	double row
2	4	2,54	5,08	40241	40251	50241	50251
3	6	5,08	7,62	40341	40351	50341	50351
4	8	7,62	10,16	40441	40451	50441	50451
5	10	10,16	12,70	40541	40551	50541	50551
6	12	12,70	15,24	40641	40651	50641	50651
7	14	15,24	17,78	40741	40751	50741	50751
8	16	17,78	20,32	40841	40851	50841	50851
9	18	20,32	22,86	40941	40951	50941	50951
10	20	22,86	25,40	41041	41051	51041	51051
11	22	25,40	27,94	41141	41151	51141	51151
12	24	27,94	30,48	41241	41251	51241	51251
13	26	30,48	33,02	41341	41351	51341	51351
14	28	33,02	35,56	41441	41451	51441	51451
15	30	35,56	38,10	41541	41551	51541	51551
16	32	38,10	40,64	41641	41651	51641	51651
17	34	40,64	43,18	41741	41751	51741	51751
18	36	43,18	45,72	41841	41851	51841	51851
19	38	45,72	48,26	41941	41951	51941	51951
20	40	48,26	50,80	42041	42051	52041	52051
21	42	50,80	53,34	42141	42151	52141	52151
22	44	53,34	55,88	42241	42251	52241	52251
23	46	55,88	58,42	42341	42351	52341	52351
24	48	58,42	60,96	42441	42451	52441	52451
25	50	60,96	63,50	42541	42551	52541	52551
26	52	63,50	66,04	42641	42651	52641	52651
27	54	66,04	68,58	42741	42751	52741	52751
28	56	68,58	71,12	42841	42851	52841	52851
29	58	71,12	73,66	42941	42951	52941	52951
30	60	73,66	76,20	43041	43051	53041	53051
31	62	76,20	78,74	43141	43151	53141	53151
32	64	78,74	81,28	43241	43251	53241	53251

Mounting block for contact pins

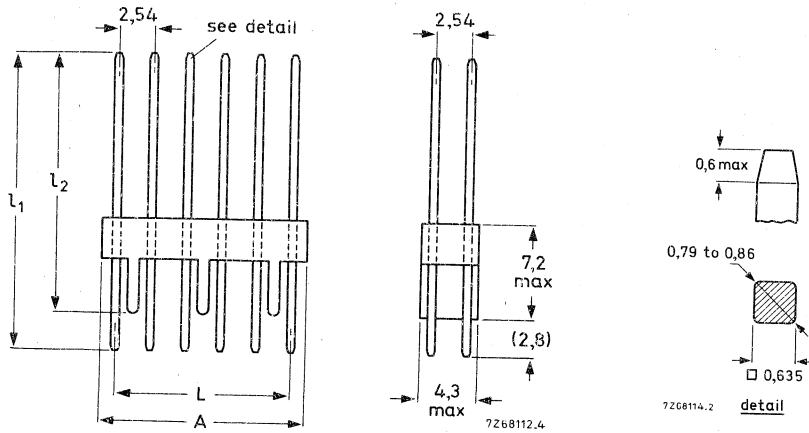

Fig. 10 Mounting block for pins, double row. See Table 5 for dimensions l_1 , l_2 , A and L.

Table 5

number of pins	l_1 *	l_2	L	A_{max}	catalogue number
2 x 10	$9,5 \pm 0,1$ $22 \pm 0,1$	$6,7 \pm 0,2$ $19,2 \pm 0,2$	$22,86 \pm 0,1$	25,4	4322 027 73710 4322 027 73750
2 x 6	$9,5 \pm 0,1$ $22 \pm 0,1$	$6,7 \pm 0,2$ $19,2 \pm 0,2$	$12,70 \pm 0,1$	15,2	4322 027 74540 4332 026 28030
2 x 4	$9,5 \pm 0,1$ $22 \pm 0,1$	$6,7 \pm 0,2$ $19,2 \pm 0,2$	$7,62 \pm 0,1$	10,1	4332 026 28050 4332 026 28040

* Other pin lengths are available on request.

Male header with 90° angled pins

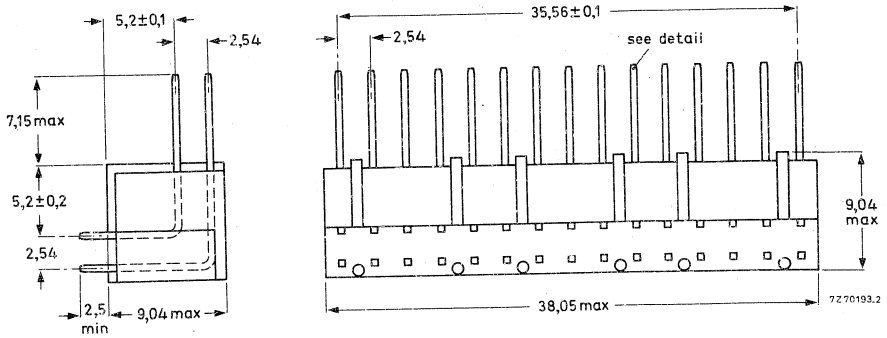
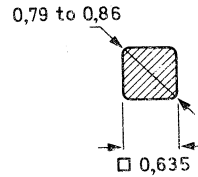
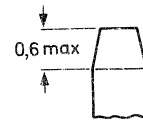

Fig. 11 Male header with 90° angled pins, double row. For the single row version, the outer row of pins is omitted.

Catalogue number of male header with 90° angled pins
 single row (15 contact pins): 2422 025 88023;
 double row (30 contact pins): 2422 025 88012.



7269114.2

detail

MOUNTING

Hole patterns on printed boards

Dimensions in mm

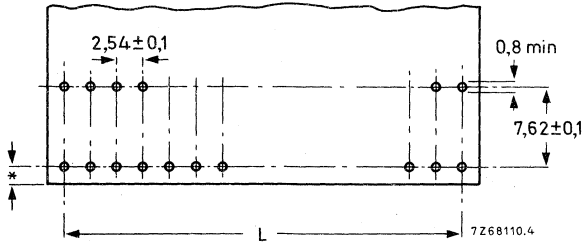

Fig. 12 Hole pattern for board edge sockets. See Table 1, pages 8 and 9 for dimension L. The dimension marked * is determined by customer application (min. 2 mm).

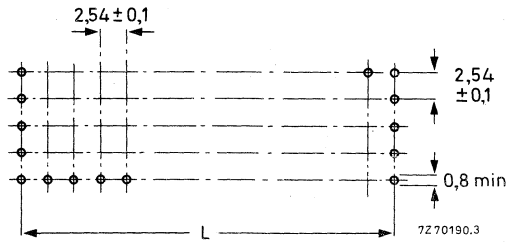

Fig. 13 Hole pattern for double-row panel sockets. See Table 2, pages 10 and 11 for dimension L.

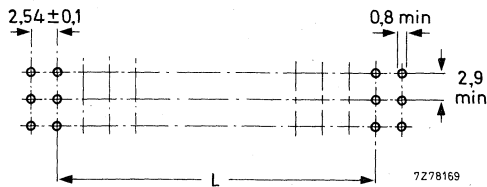

Fig. 14 Hole pattern for single-row panel sockets. See Table 2, pages 10 and 11 for dimension L.

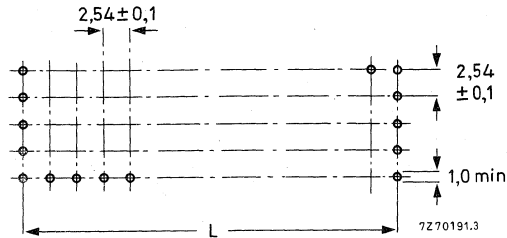

Fig. 15 Hole pattern for male headers and mounting blocks. See Table 4, page 15, for dimension L.

Crimping and mounting of contacts for cable connectors

For automatic crimping the pneumatic stripping/crimping machine PPII (Fig. 16) with a set of inserts can be supplied.

The main characteristics of the machine are:

wire to be crimped	see Table 6
crimping speed	1500 to 2000 crimps/h
compressed air consumption	0,8 l/operation
required air compression	4 to 6 atu
connection for compressed air	¼ in (gas)
dimensions	280 mm x 500 mm x 380 mm
required space	350 mm x 900 mm x 500 mm
mass	8 kg

Catalogue number of crimping machine PPII: 4332 026 29520.

Catalogue number of set of inserts: 4332 026 29530.

Table 6

wire to be crimped	wire gauge	conductor cross-section mm ²	wire diameter (including insulation) mm
stranded or solid wire	AWG24	0,196	0,5 to 1,3
	AWG26	0,126	
	AWG28	0,080	
	AWG30	0,049	

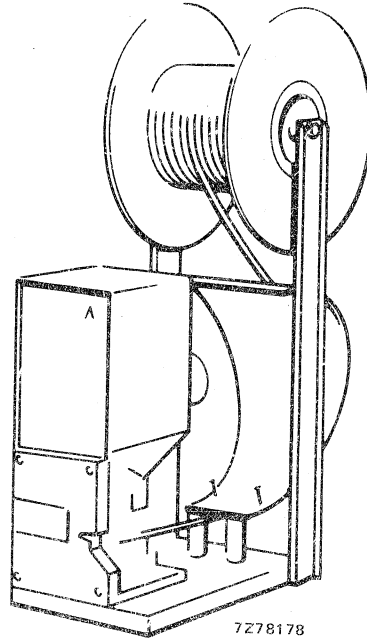

Fig. 16 Stripping/crimping machine PPII.

Hand crimping tools (Fig. 17) for different wire diameters are available; for catalogue numbers see Table 7.

Table 7

wire gauge	conductor cross-section mm ²	wire diameter (including insulation) mm	catalogue number
AWG 24	0,196	1,10 to 1,30	8222 297 81221
AWG 26, AWG 28	0,126, 0,080	0,85 to 1,20	81231
AWG 30	0,049	0,50 to 0,85	81241

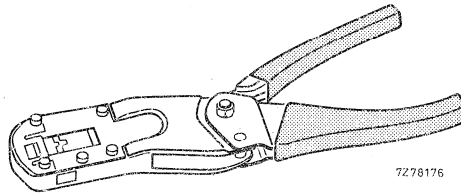

Fig. 17 Hand crimping tool.

For hand crimping cut wires to the required length and strip 3 + 0,5 mm of the insulation from the end to be crimped. Use stranded or solid wire as given in Table 6. Crimp the contact springs to the wires with the aid of the crimping tool. Snap the contact springs with the crimped wire into the cable connector.

ACCESSORIES

A phosphor-bronze key spring (Fig. 18) inserted in a contact position of the cable connector ensures that the connector is correctly polarized on its counterpart.

Catalogue number of key spring: 2422 034 15063.

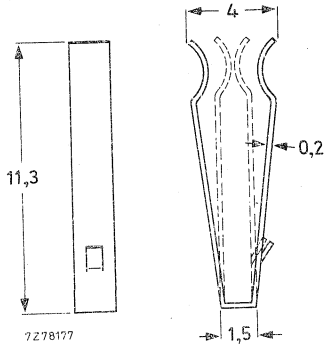
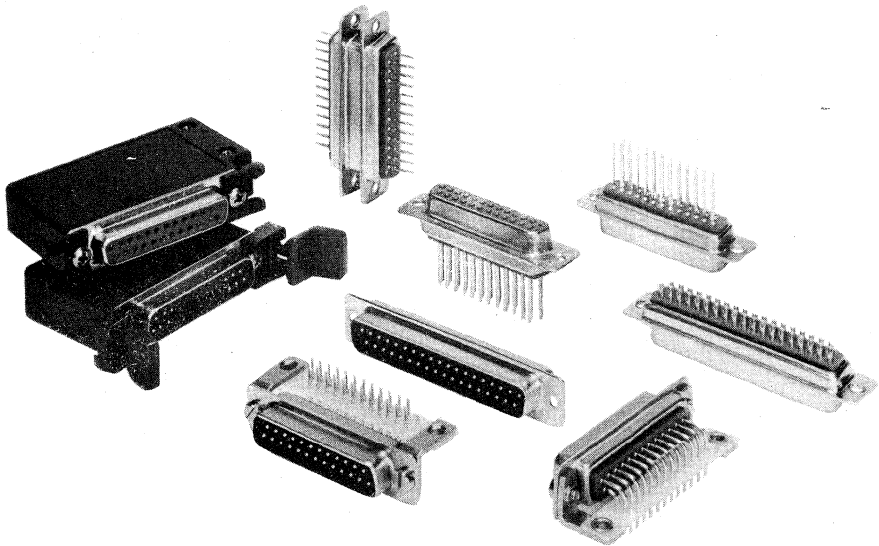

Fig. 18 Key spring for cable connector.

SUBMINIATURE RACK AND PANEL CONNECTORS

QUICK REFERENCE DATA

Number of contacts	9, 15, 25, 37 and 50
Terminations	solder cups dip-solder pins, straight or 90° angled pins for wire wrapping crimp-on snap-in
Current at $T_{amb} = 20\text{ }^{\circ}\text{C}$	7,5 A
Mechanical endurance	500 insertions
Climatic category (IEC 68)	55/125/21
Dimensions	according to MIL-STD-C-24308



Contents	
Application	page 2
Description	2
Electrical data	3
Mechanical data	4
Environmental data	5
Dimensional data	
Connectors with solder cups	6
Connectors with straight dip-solder pins	8
Connectors with 90° angled dip-solder pins	10
Connectors with pins for wire wrapping	12
Connectors for crimp-on snap-in connections	14
Mounting	16
Marking	20
Accessories	21
Packing	23

APPLICATION

For rack and panel connection in industrial, telecommunication and data processing equipment.

DESCRIPTION

The connectors consist of a red glass-fibre polycarbonate insulating block, mounted in a shell of passivated, cadmium-plated steel. The insulating block contains a number of contact pins or sockets, which are made of a copper alloy and are gold plated on a nickel layer.

Different types of pin and socket terminations are available: for hand or dip-solder, wire wrapping or crimp applications. For the latter application the contact pins and sockets are supplied as loose parts, while the insulating block of the connector contains only a number of holes allowing the crimpable pins and sockets to be loaded into the block. The contacts can be crimped with MIL-standardized tools. The connectors meet the dimensional requirements of MIL-STD-C-24308.

If a connector is to be used as a cable plug or socket, it can be fitted with a cable hood and locking device.

ELECTRICAL DATACurrent at $T_{amb} = 20\text{ }^{\circ}\text{C}$

7,5 A

Derated current curve

according to IEC 512-3,
test 5b, see Fig. 1Contact resistance (including material resistance)
at 10 mA, max. 20 mV (peak) open circuit voltage,
1 kHz, measured outside the body

initially

 $\leq 3\text{ m}\Omega$

after damp heat test

 $\leq 5\text{ m}\Omega$

Insulation resistance

initially

 $> 10^5\text{ M}\Omega$

after damp heat test

 $> 10^3\text{ M}\Omega$

Creepage distance

between contacts

 $\geq 1\text{ mm}$

between a contact and earth

 $\geq 1\text{ mm}$

Clearance distance

between contacts

 $\geq 1\text{ mm}$

between a contact and earth

 $\geq 1\text{ mm}$ Proof voltage for 1 min, at $20\text{ }^{\circ}\text{C}$

between contacts

1000 V (r.m.s.), 50 Hz

between a contact and earth

1000 V (r.m.s.), 50 Hz

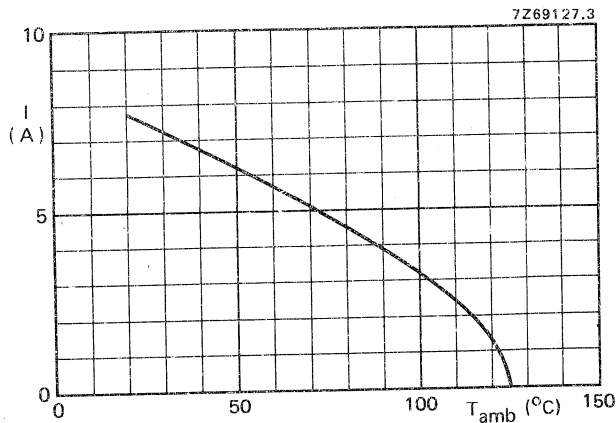

Fig. 1 Maximum current per contact, equally on all contacts, as a function of ambient temperature (20% derated).

MECHANICAL DATA

Contact pitch	see piercing diagrams, Figs 31-35
Number of contacts	9, 15, 25, 37, 50
Positioning	trapezoidal shaped shell prevents incorrect insertion
Insertion force	see Table 1
Withdrawal force	see Table 1
Mechanical endurance	500 insertions; according to IEC 512-5, test 9a
Connector body material	glass-fibre polycarbonate
Contacts	
material	copper alloy
shape	round pins and cylindrical sockets with a two-fold spring facility
finish	$\geq 0,5 \mu\text{m}$ hard gold on $\geq 2 \mu\text{m}$ nickel plating
type of termination	solder cup, dip-solder pin (straight or 90° angled), wire wrapping pin, crimp-on snap-in
Contact retention in insert	$\geq 40 \text{ N}$
Mass	see Table 1
Solderability	according to IEC 68, test T, 235°C , 2 s^*
Shock	according to IEC 68, test Ea, 50g, 11 ms, 6 directions, 3 shocks per direction
Vibration	according to IEC 68, test Fc, 10 to 2000 Hz, 0,75 mm (p-p) or 10g, 3 directions, 4 h per direction

Table 1

shell size	number of contacts	insertion force (N)	withdrawal force (N)	approx. mass (g) of complete	
				pin connector	socket connector
1	9	≤ 46	≤ 27	6	7
2	15	≤ 78	≤ 46	8	9
3	25	≤ 129	≤ 78	12	14
4	37	≤ 180	≤ 111	16	20
5	50	≤ 226	≤ 138	20	25

* Minimum distance between body and solder point: 2,5 mm.

ENVIRONMENTAL DATA

Climatic category (IEC 68)

Ambient temperature range

Damp heat, steady state

Flammability

55/125/21

-55 to + 125 °C

according to IEC 68, test Ca, 21 days,
40 °C, R.H. 90 to 95%

according to UL94, category V1



DIMENSIONAL DATA

Dimensions in mm

Connectors with solder cups (accommodate up to AWG20 stranded wire)

Connectors with 9, 15, 25 and 37 contacts

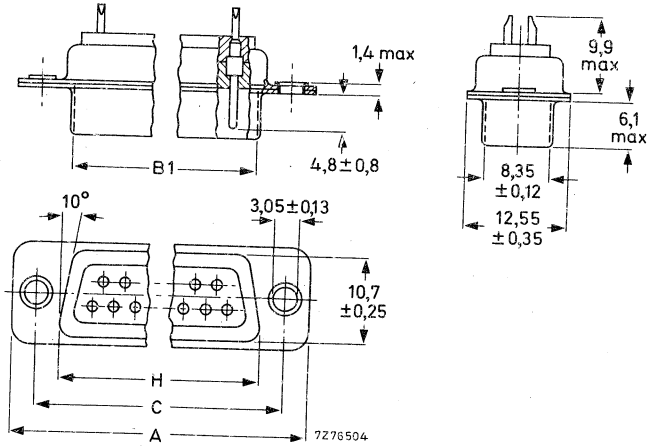

Fig. 2 Pin connector; see also Table 2.

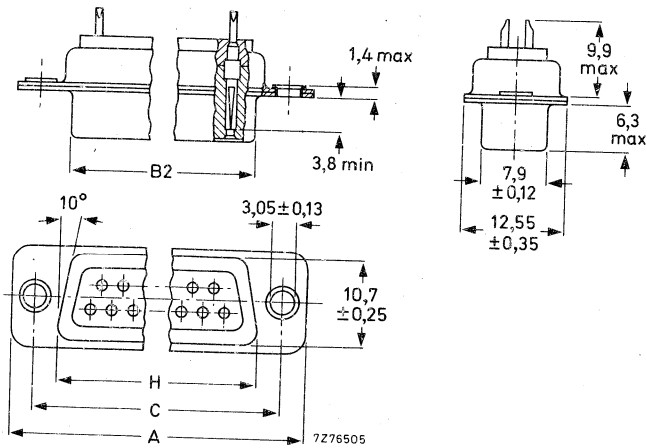

Fig. 3 Socket connector; see also Table 2.

Connectors with 50 contacts

The connectors with 50 contacts have the same dimensions as shown in the figures on the opposite page, except those shown in the figures below.

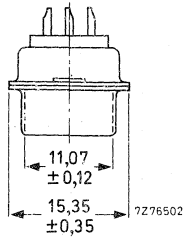

Fig. 4 Side view of pin connector.

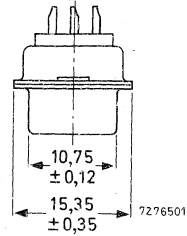

Fig. 5 Side view of socket connector.

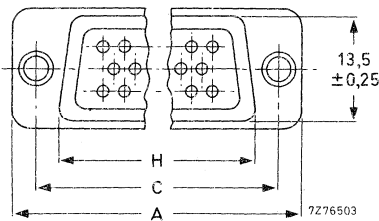

Fig. 6 Terminal side of pin (or socket) connector; see also Table 2.

Table 2

	shell size	number of contacts	dimensions (mm)					catalogue number
			A ($\pm 0,35$)	C ($\pm 0,12$)	H ($\pm 0,25$)	B1 ($\pm 0,15$)	B2 ($\pm 0,15$)	
pin connector	1	9	30,80	25,0	19,3	16,93		2422 606 20901
	2	15	39,15	33,3	27,5	25,25		21501
	3	25	53,00	47,05	41,3	39,00		22501
	4	37	69,30	63,5	57,7	55,45		23701
	5	50	66,90	61,1	55,3	52,83		25001
socket connector	1	9	30,80	25,0	19,3		16,30	2422 606 30901
	2	15	39,15	33,3	27,5		24,65	31501
	3	25	53,00	47,05	41,3		38,35	32501
	4	37	69,30	63,5	57,7		54,80	33701
	5	50	66,90	61,1	55,3		52,40	35001

Note: See *Mechanical Data* for solder conditions.

Connectors with straight dip-solder pins (see also piercing diagrams, Figs 31 to 35)

Connectors with 9, 15, 25 and 37 contacts

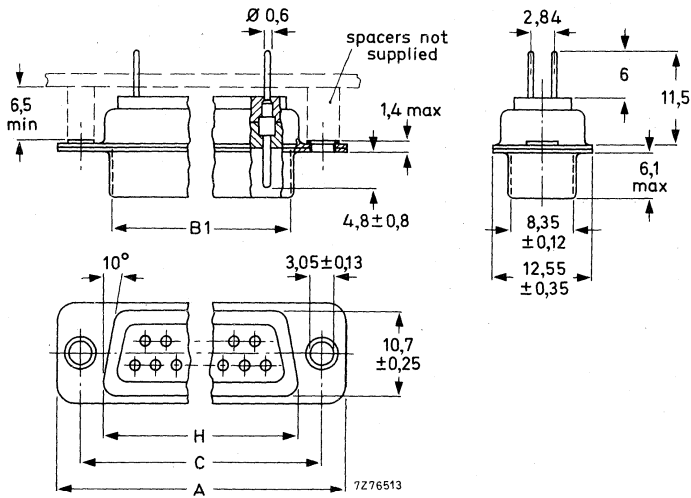

Fig. 7 Pin connector; see also Table 3.

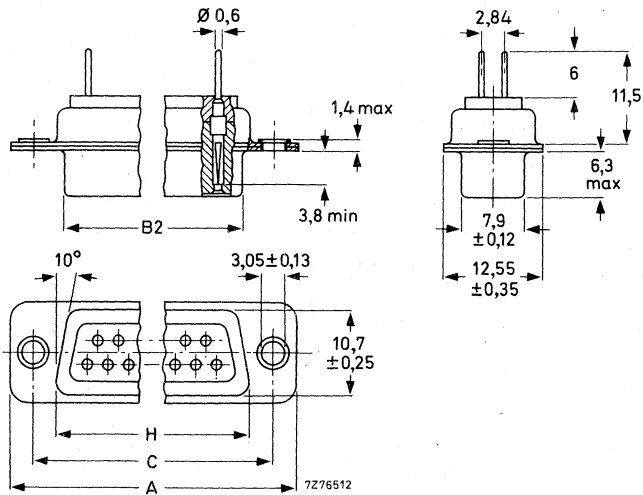

Fig. 8 Socket connector; see also Table 3.

Connectors with 50 contacts

The connectors with 50 contacts have the same dimensions as shown in the figures on the opposite page, except those shown in the figures below.

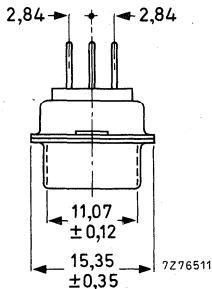

Fig. 9 Side view of pin connector.

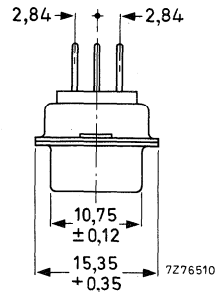

Fig. 10 Side view of socket connector.

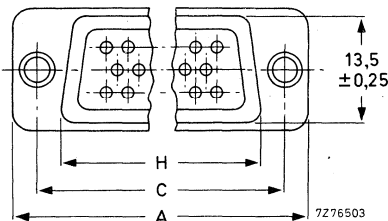

Fig. 11 Terminal side of pin (or socket) connector; see also Table 3.

Table 3

	shell size	number of contacts	dimensions in (mm)					catalogue number
			A (± 0,35)	C (± 0,12)	H (± 0,25)	B1 (± 0,15)	B2 (± 0,15)	
pin connector	1	9	30,80	25,0	19,3	16,93		2422 606 60901
	2	15	39,15	33,3	27,5	25,25		61501
	3	25	53,00	47,05	41,3	39,00		62501
	4	37	69,30	63,5	57,7	55,45		63701
	5	50	66,90	61,1	55,3	52,83		65001
socket connector	1	9	30,80	25,0	19,3		16,30	2422 606 70901
	2	15	39,15	33,3	27,5		24,65	71501
	3	25	53,00	47,05	41,3		38,35	72501
	4	37	69,30	63,5	57,7		54,80	73701
	5	50	66,90	61,1	55,3		52,40	75001

Note: See *Mechanical Data* for solder conditions.

Connectors with 90° angled dip-solder pins (see also piercing diagrams, Figs 31 to 35)

Connectors with 9, 15, 25 and 37 contacts

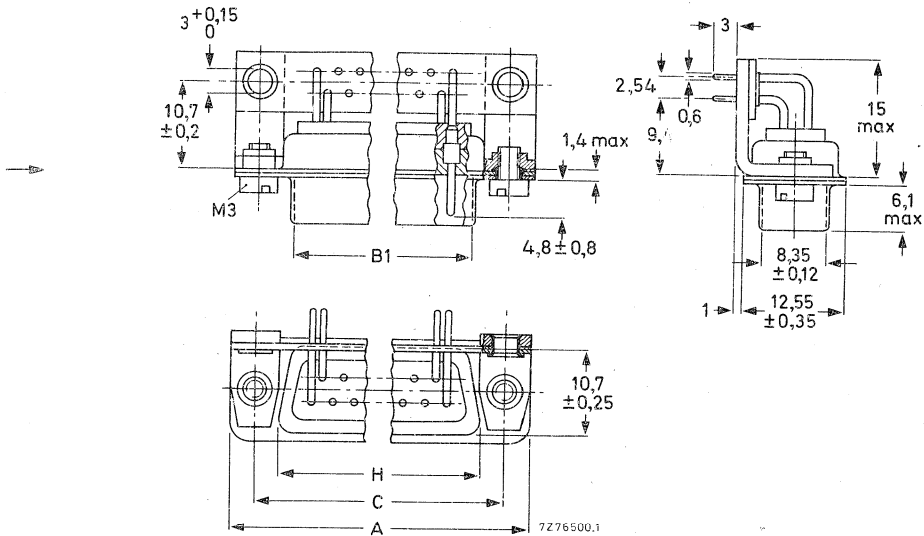

Fig. 12 Pin connector; see also Table 4.

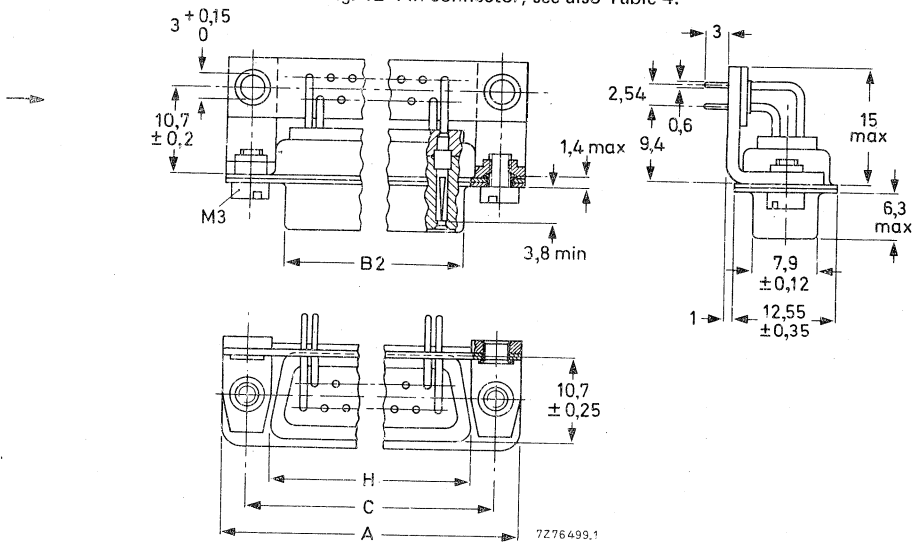

Fig. 13 Socket connector; see also Table 4.

Connectors with 50 contacts

The connectors with 50 contacts have the same dimensions as shown in the figures on the opposite page, except those shown in the figures below.

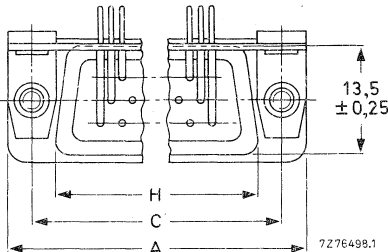
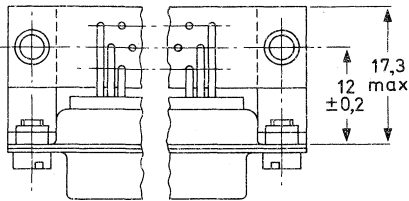

Fig. 14 Pin connector; see also Table 4.

Fig. 16 Side view of socket connector.

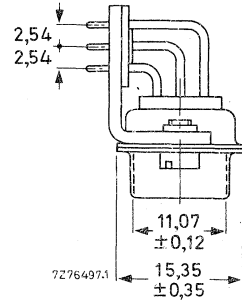

Fig. 15 Side view of pin connector.

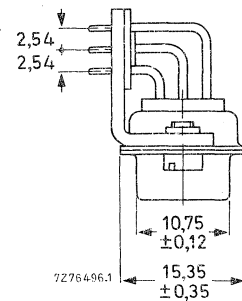

Table 4

	shell size	number of contacts	dimensions (mm)					catalogue number
			A (± 0,35)	C (± 0,12)	H (± 0,25)	B1 (± 0,15)	B2 (± 0,15)	
pin connector	1	9	30,80	25,0	19,3	16,93		2422 606 80901
	2	15	39,15	33,3	27,5	25,25		81501
	3	25	53,00	47,05	41,3	39,00		82501
	4	37	69,30	63,5	57,7	55,45		83701
	5	50	66,90	61,1	55,3	52,83		85001
socket connector	1	9	30,80	25,0	19,3		16,30	2422 606 90901
	2	15	39,15	33,3	27,5		24,65	91501
	3	25	53,00	47,05	41,3		38,35	92501
	4	37	69,30	63,5	57,7		54,80	93701
	5	50	66,90	61,1	55,3		52,40	95001

Note: See *Mechanical Data* for solder conditions.

Connectors with wire wrapping pins (accommodate AWG28 and AWG30 wire; 0,32 and 0,25 mm dia.)
 Connectors with 9, 15, 25 and 37 contacts

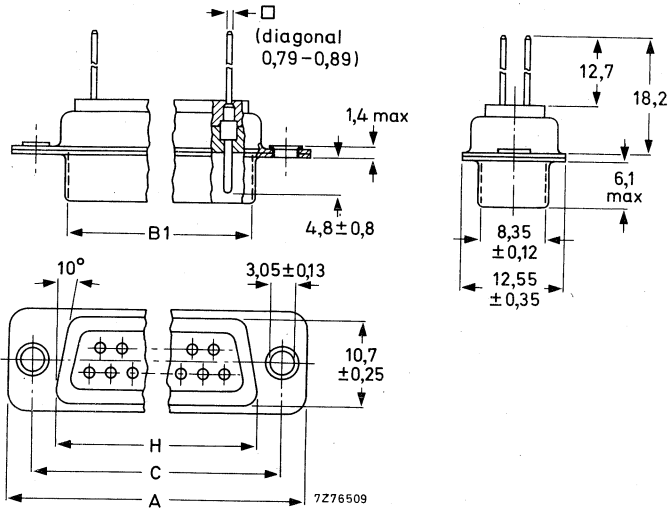

Fig. 17 Pin connector; see also Table 5.

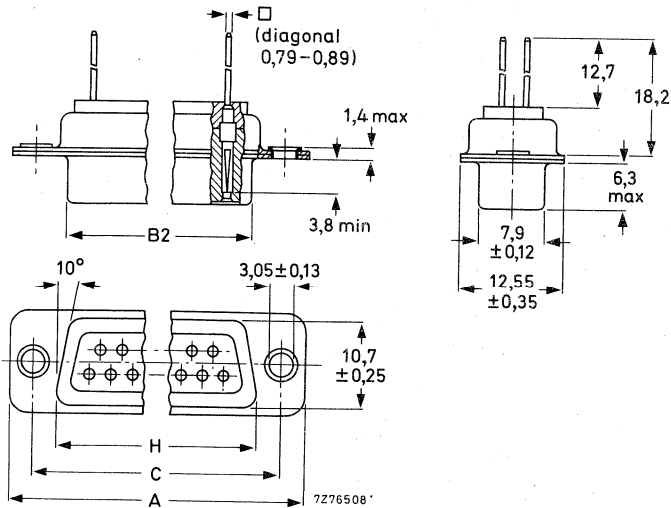

Fig. 18 Socket connector; see also Table 5.

Connectors with 50 contacts

The connectors with 50 contacts have the same dimensions as shown in the figures on the opposite page, except those shown in the figures below.

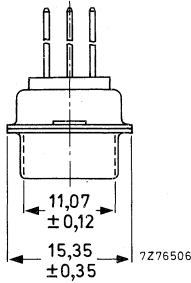

Fig. 19 Side view of pin connector.

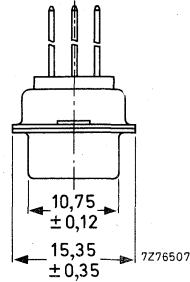

Fig. 20 Side view of socket connector.

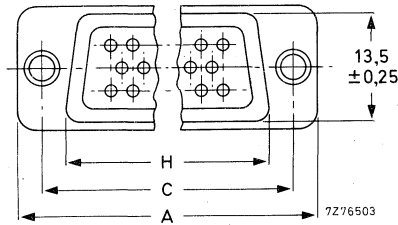

Fig. 21 Terminal side of pin (or socket) connector; see also Table 5.

Table 5

	shell size	number of contacts	dimensions (mm)					catalogue number
			A (± 0,35)	C (± 0,12)	H (± 0,25)	B1 (± 0,15)	B2 (± 0,15)	
pin connector	1	9	30,80	25,0	19,3	16,93		2422 606 40901
	2	15	39,15	33,3	27,5	25,25		41501
	3	25	53,00	47,05	41,3	39,00		42501
	4	37	69,30	63,5	57,7	55,45		43701
	5	50	66,90	61,1	55,3	52,83		45001
socket connector	1	9	30,80	25,0	19,3		16,30	2422 606 50901
	2	15	39,15	33,3	27,5		24,65	51501
	3	25	53,00	47,05	41,3		38,35	52501
	4	37	69,30	63,5	57,7		54,80	53701
	5	50	66,90	61,1	55,3		52,40	55001

Connectors for crimp-on snap-in connections (accommodate AWG20 to AWG24 wire; 0,6 to 0,23 mm²). These connectors are supplied without contacts; loose crimp contact pins and sockets are available.

Connectors for 9, 15, 25 and 37 contacts

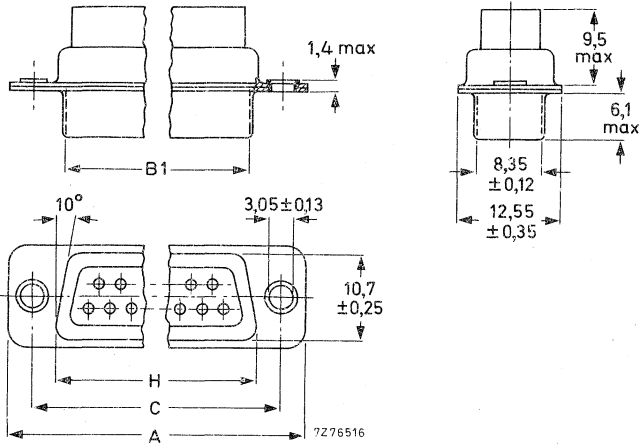

Fig. 22 Pin connector; see also Table 6.

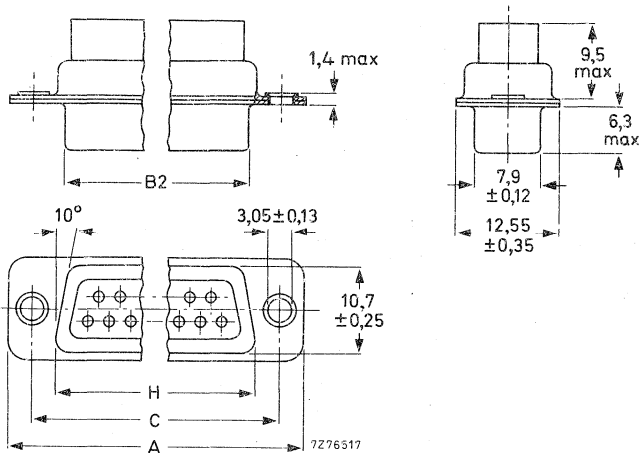

Fig. 23 Socket connector; see also Table 6.

Connectors for 50 contacts

The connectors for 50 contacts have the same dimensions as shown in the figures on the opposite page, except those shown in the figures below.

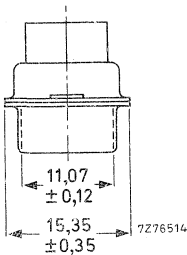

Fig. 24 Side view of pin connector

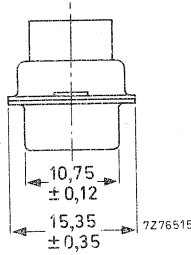

Fig. 25 Side view of socket connector.

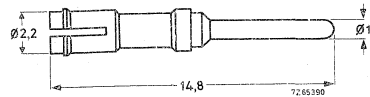

Fig. 27 Crimp contact pin.

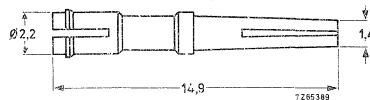

Fig. 28 Crimp contact socket.

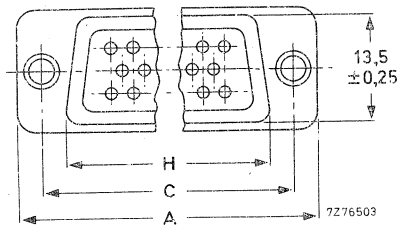

Fig. 26 Terminal side of pin (or socket) connector; see also Table 6.

Table 6

	shell size	number of contacts	dimensions (mm)					catalogue number
			A (± 0,35)	C (± 0,12)	H (± 0,25)	B1 (± 0,15)	B2 (± 0,15)	
pin connector	1	9	30,80	25,0	19,3	16,93		4332 026 22400 22420 22440 22460 22480
	2	15	39,15	33,3	27,5	25,25		
	3	25	53,00	47,05	41,3	39,00		
	4	37	69,30	63,5	57,7	55,45		
	5	50	66,90	61,1	55,3	52,83		
socket connector	1	9	30,80	25,0	19,3		16,30	4332 026 22410 22430 22450 22470 22490
	2	15	39,15	33,3	27,5		24,65	
	3	25	53,00	47,05	41,3		38,35	
	4	37	69,30	63,5	57,7		54,80	
	5	50	66,90	61,1	55,3		52,40	

Catalogue number of crimp contact pin 4332 026 19690.
 Catalogue number of crimp contact socket 4332 026 19700.

MOUNTING

Panel cut-outs for all versions

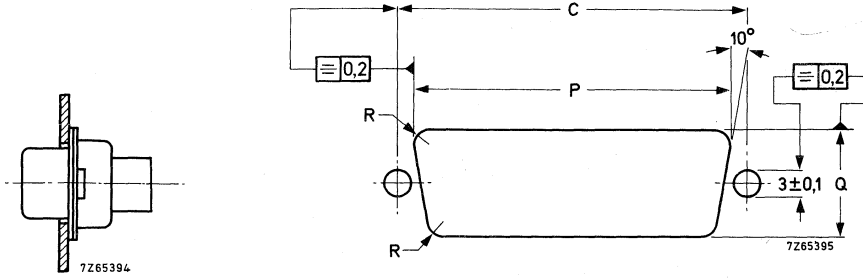

Fig. 29 Rear flange mounting.

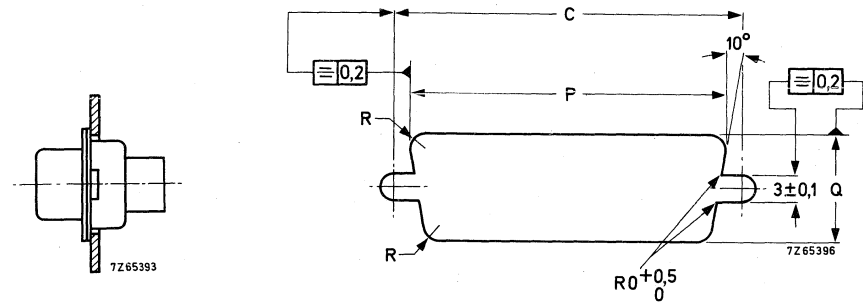

Fig. 30 Front flange mounting.

Table 7

mounting method	shell size	number of contacts	C ± 0,2	P ± 0,2	Q ± 0,2	R ± 0,2
rear flange mounting	1	9	25,0	20,5	11,4	3,4
	2	15	33,3	28,8	11,4	3,4
	3	25	47,0	42,5	11,4	3,4
	4	37	63,5	59,1	11,4	3,4
	5	50	61,1	56,3	14,1	3,4
front flange mounting	1	9	25,0	22,2	12,3	2,1
	2	15	33,3	30,5	12,3	2,1
	3	25	47,0	44,3	12,3	2,1
	4	37	63,5	60,7	12,3	2,1
	5	50	61,1	58,3	15,3	2,1

Piercing diagrams for connectors with straight or 90° angled dip-solder pins

Notes

The pitch tolerances are $\pm 0,05$ mm.

The contact pitch X is $2,84 \pm 0,05$ mm for straight dip-solder pins, and $2,54 \pm 0,05$ mm for 90° angled dip-solder pins.

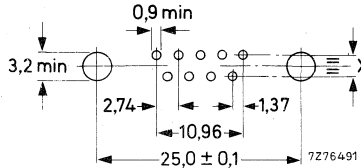

Fig. 31 For 9 contacts.

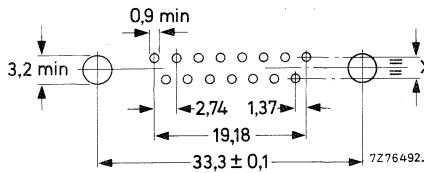

Fig. 32 For 15 contacts.

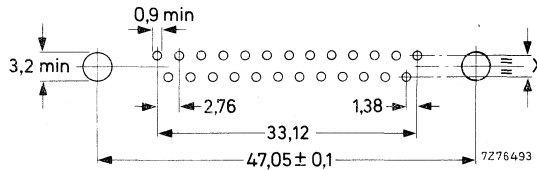

Fig. 33 For 25 contacts.

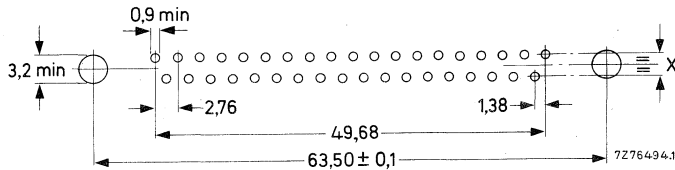

Fig. 34 For 37 contacts.

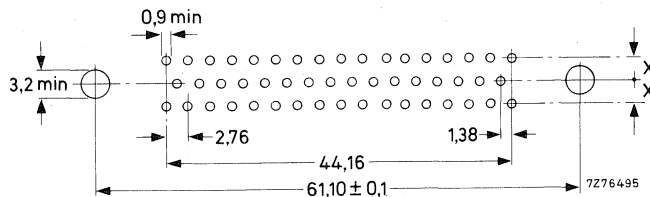

Fig. 35 For 50 contacts.

Crimping and mounting of contacts for crimp connections

Mounting tools

Contact insertion tool (white), see Fig. 36: catalogue number 4332 026 22500.

Contact extraction tool (red), see Fig. 37: catalogue number 4332 026 22510.

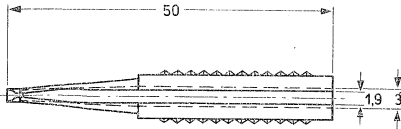

Fig. 36 Insertion tool (white).

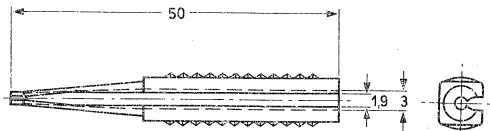

Fig. 37 Extraction tool (red).

7265125.1

Wire stripping

Cut the wires to the required length and strip a part of the insulation from the end to be crimped, as shown in Figs 38 and 39, depending on the diameter of the wire.

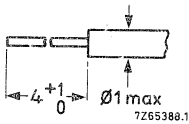

Fig. 38 Wire diameter max. 1 mm.

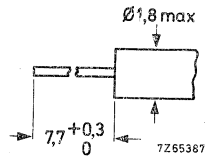

Fig. 39 Wire diameter greater than 1 mm (max. 1,8 mm).

Contact crimping

Fit the positioner into the crimping tool and insert the contact pin or the contact socket. Push the stripped end of the wire as far as possible into the back of the pin or socket and crimp the contact to the wire. (For cables with a diameter greater than 1 mm, the insulation remains outside the contact end.)

Contact insertion

Push the pin or socket by hand from the rear into the requisite hole in the insulating block until it fits. For wires with AWG24 ($0,23 \text{ mm}^2$) use the white insertion tool shown in Fig. 36: place the pin or socket in the groove of the tool and insert the pin or socket into the hole of the insulating block until it fits.

Contact extraction (rear release system)

Place the wire into the groove of the red extraction tool (Fig. 37). Push the tool from the rear into the hole of the insulating block until it touches the ledge (contact is unlocked). Release the tool and pull on the wire (contact is free).

Contact crimping tools

Crimping of contacts can be effected with the following tools:

	catalogue number	Buchanan* catalogue number
(a) Hand crimping tool, MS 3198-1	2622 540 10004	612596
Positioner to hand crimping tool, MS 3198-5P	2622 540 10907	613533

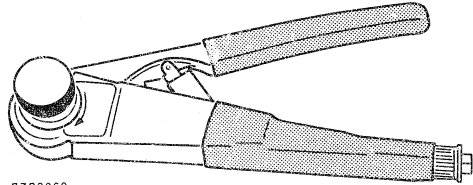

7270669

Fig. 40 Hand crimping tool.

	catalogue number	Buchanan* catalogue number
(b) Manual feed pneumatic crimping tool	2622 540 10003	612768
Bench mount assembly	2622 540 10906	11380
Positioner for pin and socket contact with ejector	2622 540 10905	616265
Positioner for pin contact	4332 026 26970	
Positioner for socket contact	4332 026 26980	
Contact feeder	4332 026 26960	
Gauge pin for AWG20 (0,6 mm ²)	4332 026 26930	
Gauge pin for AWG22 (0,36 mm ²)	4332 026 26940	
Gauge pin for AWG24 (0,23 mm ²)	4332 026 26950	

Notes

The use of the contact feeder facilitates the contact positioning. The feeder can be fitted by means of the four screws of the crimping tool.

The gauge pins for adjustment and control of crimp depth are also suitable for check with hand tool.

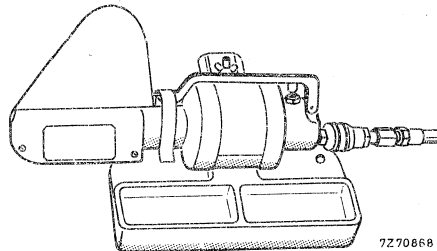

7270668

Fig. 41 Pneumatic crimping tool.

* Registered trade name of Buchanan Electrical Products Corporation.

MARKING

Package

The package is marked with: 12-digit catalogue number;
reference number of manufacturer;
number of pieces.

Connector

The terminations of the connectors are marked as shown in Table 8.

Table 8

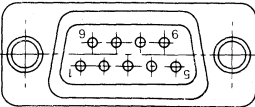
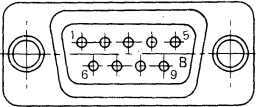
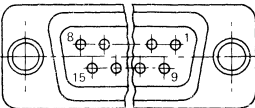
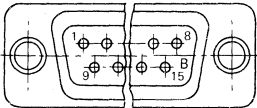
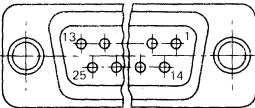
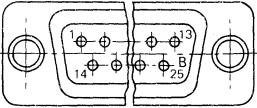
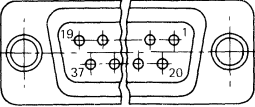
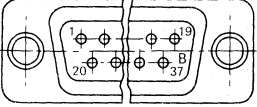
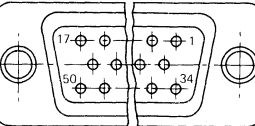
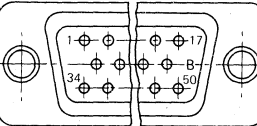
shell size	number of contacts	pin connector	socket connector
1	9		
2	15		
3	25		
4	37		
5	50		

7.2.75.243

ACCESSORIES

Cable hoods

Hoods of thermoplastic material for cable mounting can be supplied in two versions: straight and 90° angled. A cable clamp and two screws are supplied with each hood. Also supplied are two screws to secure the hood to the connector.

Table 9

version	shell size	number of contacts	dimensions (mm)					catalogue number
			1	w	d	p	q	
straight (Fig. 42)	1	9	28	31	12,7	7,5	8	4332 026 23690 23740 23790 23840 23890
	2	15	29	39,2	12,7	8,6	9	
	3	25	34	53	12,7	14	9	
	4	37	40	69,5	12,7	20	9	
	5	50	40	67	15,5	20	12	
90° angled (Fig. 43)	1	9	28	39	12,7	7,5	8	4332 026 23710 23760 23810 23860 23910
	2	15	29	47,2	12,7	8,6	9	
	3	25	34	61	12,7	14	9	
	4	37	40	77,5	12,7	20	9	
	5	50	40	75	15,5	20	12	

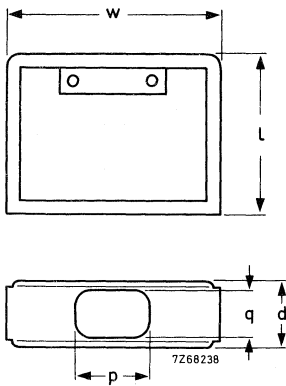

Fig. 42 Straight cable hood.

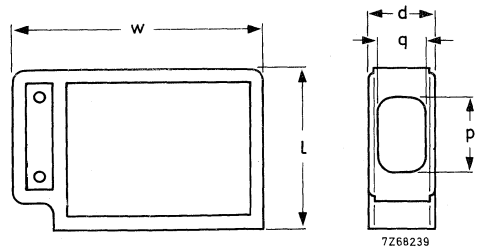

Fig. 43 90° angled cable hood.

Locking devices

Locking clips and handles of thermoplastic material are available for locking pin connectors to socket connectors (see Fig. 44).

Use must be made of:

2 x handle 4322 026 24350 and

2 x clip 4332 026 24070.

For locking a 90° angled cable hood use must be made of:

1 x handle 4332 026 24350

1 x handle (90° angled) 4332 026 24360 and

2 x clip 4332 026 24070.

The locking devices are secured with the fixing screws of the hoods.

If locking devices are used without the cable hoods shown in Figs 42 and 43, they can be secured with ordinary screws and nuts.

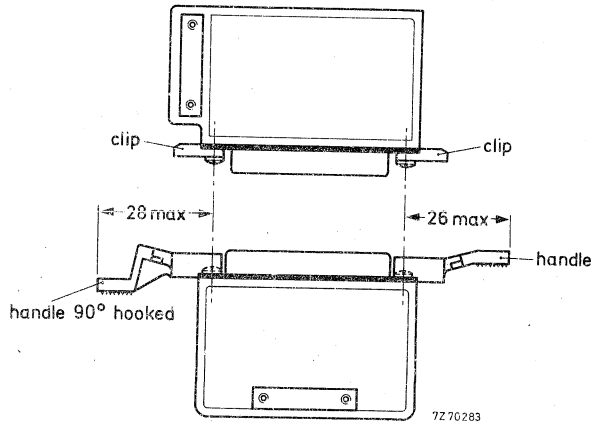

Fig. 44.

PACKING**Connectors**

The connectors are packed in boxes. The number of connectors per box is given in Table 10.

Table 10

shell size	number of connectors per box	
	type with 90° angled pins	other types
1	170	170
2	130	140
3	90	100
4	70	70
5	35	80

Please order in multiples of these quantities.

Cable hoods

The cable hoods are packed in plastic bags, containing 5 hoods and associated clamps and screws; please order in multiples of this quantity.

Locking devices

The locking devices are packed in plastic bags; handles 50 per bag; clips 100 per bag. Please order in multiples of these quantities.

Electronic components and materials for professional, industrial and consumer uses from the world-wide Philips Group of Companies

- Argentina:** FAPESA I.y.C., Av. Crovara 2550, Tablada, Prov. de BUENOS AIRES, Tel. 652-7438/7478.
- Australia:** PHILIPS INDUSTRIES HOLDINGS LTD., Elcoma Division, 67 Mars Road, LANE COVE, 2066, N.S.W., Tel. 427 08 88.
- Austria:** ÖSTERREICHISCHE PHILIPS BAUELEMENTE Industrie G.m.b.H., Triester Str. 64, A-1101 WIEN, Tel. 62 91 11.
- Belgium:** M.B.L.E., 80, rue des Deux Gares, B-1070 BRUXELLES, Tel 523 00 00.
- Brazil:** IBRAPE, Caixa Postal 7383, Av. Paulista 2073-S/Loja, SAO PAULO, SP, Tel. 284-4511.
- Canada:** PHILIPS ELECTRONICS LTD., Electron Devices Div., 601 Milner Ave., SCARBOROUGH, Ontario, M1B 1M8, Tel. 292-5161.
- Chile:** PHILIPS CHILENA S.A., Av. Santa Maria 0760, SANTIAGO, Tel. 39-40 01.
- Colombia:** SADAPE S.A., P.O. Box 9805, Calle 13, No. 51 + 39, BOGOTA D.E. 1., Tel. 600 600.
- Denmark:** MINIWATT A/S, Emdrupvej 115A, DK-2400 KØBENHAVN NV., Tel. (01) 69 16 22.
- Finland:** OY PHILIPS AB, Elcoma Division, Kaivokatu 8, SF-00100 HELSINKI 10, Tel. 1 72 71.
- France:** R.T.C. LA RADIOTECHNIQUE-COMPELEC, 130 Avenue Ledru Rollin, F-75540 PARIS 11, Tel. 355-44-99.
- Germany:** VALVO, UB Bauelemente der Philips G.m.b.H., Valvo Haus, Burchardstrasse 19, D-2 HAMBURG 1, Tel. (040) 3296-1.
- Greece:** PHILIPS S.A. HELLENIQUE, Elcoma Division, 52, Av. Syngrou, ATHENS, Tel. 915 311.
- Hong Kong:** PHILIPS HONG KONG LTD., Comp. Dept., Philips Ind. Bldg., Kung Yip St., K.C.T.L. 289, KWAI CHUNG, N.T. Tel. 12-24 51 21.
- India:** PHILIPS INDIA LTD., Elcoma Div., Band Box House, 254-D, Dr. Annie Besant Rd., Prabhadevi, BOMBAY-25-DD, Tel. 457 311-5.
- Indonesia:** P.T. PHILIPS-RALIN ELECTRONICS, Elcoma Division, 'Timah' Building, Jl. Jen. Gatot Subroto, JAKARTA, Tel. 44 163.
- Ireland:** PHILIPS ELECTRICAL (IRELAND) LTD., Newstead, Clonskeagh, DUBLIN 14, Tel. 69 33 55.
- Italy:** PHILIPS S.p.A., Sezione Elcoma, Piazza IV Novembre 3, I-20124 MILANO, Tel. 2-6994.
- Japan:** NIHON PHILIPS CORP., Shuwa Shinagawa Bldg., 26-33 Takanawa 3-chome, Minato-ku, TOKYO (108), Tel. 448-5611.
(IC Products) SIGNETICS JAPAN, LTD., TOKYO, Tel. (03) 230-1521.
- Korea:** PHILIPS ELECTRONICS (KOREA) LTD., Philips House, 260-199 Itaewon-dong, Yongsan-ku, C.P.O. Box 3680, SEOUL, Tel. 44-4202.
- Mexico:** ELECTRONICA S.A. de C.V., Varsovia No. 36, MEXICO 6, D.F., Tel. 5-33-11-80.
- Netherlands:** PHILIPS NEDERLAND B.V., Afd. Elonco, Boschdijk 525, NL-4510 EINDHOVEN, Tel. (040) 79 33 33.
- New Zealand:** Philips Electrical Ind. Ltd., Elcoma Division, 2 Wagener Place, St. Lukes, AUCKLAND, Tel. 867 119.
- Norway:** ELECTRONICA A/S., Vitaminveien 11, P.O. Box 29, Grefsen, OSLO 4, Tel. (02) 15 05 90.
- Peru:** CADESA, Jr. Ilo, No. 216, Apartado 10132, LIMA, Tel. 27 73 17.
- Philippines:** ELDAC, Philips Industrial Dev. Inc., 2246 Pasong Tamo, MAKATI-RIZAL, Tel. 86-89-51 to 59.
- Portugal:** PHILIPS PORTUGESA S.A.R.L., Av. Eng. Duarte Pacheco 6, LISBOA 1, Tel. 68 31 21.
- Singapore:** PHILIPS SINGAPORE PTE LTD., Elcoma Div., POB 340, Toa Payoh CPO, Lorong 1, Toa Payoh, SINGAPORE 12, Tel. 53 88 11.
- South Africa:** EDAC (Pty.) Ltd., South Park Lane, New Doornfontein, JOHANNESBURG 2001, Tel. 24/6701.
- Spain:** COPRESA S.A., Balmes 22, BARCELONA 7, Tel. 301 63 12.
- Sweden:** A.B. ELCOMA, Lidingsvägen 50, S-10 250 STOCKHOLM 27, Tel. 08/67 97-80.
- Switzerland:** PHILIPS A.G., Elcoma Dept., Edenstrasse 20, CH-8027 ZÜRICH, Tel. 01/44 22 11.
- Taiwan:** PHILIPS TAIWAN LTD., 3rd Fl., San Min Building, 57-1, Chung Shan N. Rd, Section 2, P.O. Box 22978, TAIPEI, Tel. 5513101-5.
- Turkey:** TÜRK PHILIPS TICARET A. S., EMET Department, Inonu Cad. No. 78-80, ISTANBUL, Tel. 43 59 10.
- United Kingdom:** MULLARD LTD., Mullard House, Torrington Place, LONDON WC1E 7HD, Tel. 01-580 6633.
- United States:** (Active devices & Materials) AMPEREX SALES CORP., Providence Pike, SLATERSVILLE, R.I. 02876, Tel. (401) 762-9000.
(Passive devices) MEPCO/ELECTRA INC., Columbia Rd., MORRISTOWN, N.J. 07960, Tel. (201) 539-2000.
(IC Products) SIGNETICS CORPORATION, 811 East Arques Avenue, SUNNYVALE, California 94086, Tel. (408) 739-7700.
- Uruguay:** LUZILECTRON S.A., Rondeau 1567, piso 5, MONTEVIDEO, Tel. 9 43 21.
- Venezuela:** IND. VENEZOLANAS PHILIPS S.A., Elcoma Dept., A. Ppal de los Ruices, Edif. Centro Colgate, Apdo 1167, CARACAS, Tel. 36 05 11.